



China patent No.:ZL201520680239.8

Multi-functional Flow Control Valve for Water Treatment Systems

63505 (F116A1)
63605 (F116A3)
63503 (F117A1)
63603 (F117A3)

User Manual

WENZHOU RUNXIN MANUFACTURING MACHINE CO.,LTD

ADD: NO.169, RUNXIN ROAD, SHANFU TOWN, WENZHOU, ZHEJIANG, CHINA.
TEL.:0086-577-88630038, 88576512, 85956057 FAX:0086-577-88633258
E-MAIL: sales@run-xin.com <http://www.run-xin.com>

Rev.A.2208





Please read this manual in details
before using the valve and keep it properly
in order to consult in the future
0WRX.466.649

MODEL: F116A1/F116A3/F117A1/F117A3

Before the valve put into use, please fill in the below content so as to help us to refer in the future.

The Program Type Setting (Operation by professional)

When all symbols light on, press and hold  and  buttons for 5 seconds to enter the menu of valve model selection. Please set the program type in accordance with the product type.

Softener System Configuration

Tank Size: Dia. _____ mm; Height _____ mm;
 Resin Volume _____ L; Brine Tank Capacity _____ L;
 Hardness of Raw Water _____ mmol/L; Pressure of Inlet Water _____ MPa;
 Control Valve Model _____ ; Number _____ ;
 The Specification of Drain Line Flow Control _____ ;
 The Specification of Brine Line Flow Control _____ ;
 Injector No. _____ .
 Water Source (Optional): Ground-water Filtered Ground-water
 Tap Water Other _____ .

Parameter Set

Parameter	Unit	Factory Default	Actual Value
Control Mode A-01 (02, 03,04)	/	A-01	
Unit Mode HU-01 (02, 03)	/	HU-01	
Water Treatment Capacity (Meter type)	m ³	10.00	
Service Days (Time clock type, by days)	D	03	
Service Hours (Time clock type, by hours)	H	20	
Regeneration Time	/	02:00	
Backwash Time	min.	10	
Brine & Slow Rinse Time	min.	60	
Brine Refill Time	min.	05	
Fast Rinse Time	min.	10	
Interval Regeneration Days	D	30	
Output Mode b-01 (02)	/	b-01	

● If there is no special requirement when purchase F116, we choose 9# injector and no drain line flow control for the standard configuration, for F117, we choose 7# injector and 8468062 drain line flow control for the standard configuration.

MODEL: F116A1/F116A3/F117A1/F117A3

Catalogue

Notice ----- 1

1. Product Overview ----- 2

 1.1. Main Application & Applicability ----- 2

 1.2. Product Characteristics ----- 2

 1.3. Service Condition ----- 4

 1.4. Product Structure and Technical Parameters ----- 5

 1.5. Installation ----- 6

2. Basic Setting & Usage ----- 9

 2.1. The Function of PC Board ----- 9

 2.2. Basic Setting & Usage ----- 11

3. Applications ----- 14

 3.1. Softener Flow Chart ----- 14

 3.2. The Function and Connection of PC Board ----- 14

 A. Signal Output Connector ----- 15

 B. Interlock ----- 18

 C. Pressure Relief Output ----- 18

 D. Remote Handling Connector ----- 19

 E. Interlock System ----- 19

 F. Series System ----- 20

 3.3. System Configuration and Flow Rate Curve ----- 20

 3.4. Parameter Settlement ----- 22

 3.5. Parameter Enquiry and Setting ----- 24

 3.6. Trial Running ----- 27

 3.7. Trouble-Shooting ----- 28

 3.8. Assembly & Parts ----- 31

4. Warranty Card ----- 37

Notice

- To ensure normal operation of the valve, please consult with professional installation or repairing personnel before use it.
- If there are any of pipeline engineering and electric works, there must be finished by professional at the time of installation.
- Do not use the control valve with the water that is unsafe or unknown quality.
- Depending on the changing of working environment and water requirement, each parameter of softener should be adjusted accordingly.
- When the water treatment capacity is too low, please check the resin. If the reason is short of resin, please add; if the resin is turn to reddish brown or broken, please replace.
- Test water periodically to verify that system is performing satisfactorily.
- Sodium used in the water softening process should be considered as part of your overall dietary salt intake. Contact doctor if you are on a low sodium diet.
- Ensure that there is solid salt all the time in the brine tank in the course of using, when this valve is used for softening. The brine tank should be added crystalline coarse salt only, at least 99.5% pure, forbidding use the small salt.
- Do not put the valve near heat sources or surroundings with high humidity, corrosive, intense magnetic field or intense vibrations environment. And do not leave it outside.
- Forbidden to carry the injector body. Avoid to use injector body as support to carry the system.
- Forbidden to use the brine tube or other connectors as support to carry the system.
- Please use this product under the water temperature between 5~50℃, water pressure 0.15~0.6MPa. Failure to use this product under such conditions voids the warranty.
- If the water pressure exceeds 0.6MPa, a pressure reducing valve must be installed before the water inlet. While, if the water pressure under is 0.15MPa, a booster pump must be installed before the water inlet.
- PPR pipes, corrugated pipes, or UPVC pipes are recommended for pipe installation and aluminum-plastic pipes should be avoided.
- Do not let children touch or play, because careless operations may cause the procedure changed.
- When the attached cables of this product and transformer are damaged, they must be changed to the one that is from our factory.

1.Product Overview**1.1.Main Application & Applicability**

Used for softening or demineralization water treatment systems.

Be suitable for

- Residential softening system,
- Ion exchange equipment
- Boiler softening water system
- RO pretreatment softening system, etc.

1.2. Product Characteristics**● Simple structure and reliable sealing**

It adopts hermetic head faces with high degree pottery and corrosion resistance for opening and closing. It combines with Service, Backwash, Brine & Slow Rinse, Brine Refill and Fast Rinse.

● No water pass the valve in regeneration in single tank type.**● Manual function**

Realize regeneration immediately by pressing  at any time.



● Long outage indicator

If outage overrides 3 days, the time of day indicator "12:12" will flash to remind people to reset new time of day. The other set parameters do not need resetting. The process will continue to work after power on.



● LED dynamic screen display

The stripe on dynamic screen flash, it indicates the control valve is in service, otherwise, it is in regeneration cycle.

● Buttons lock

No operations to buttons on the controller within 1 minute, button lock indicator lights on which represent buttons are locked. Before operation, press and hold  and  buttons for 5 seconds to unlock. This function can avoid incorrect operation.

● It can choose time clock type or meter type by program selection

When all symbols light on, press and hold  and  buttons for 5 seconds to enter the menu of valve model selection. Please set the program type in accordance with the product type. (Time clock type by days or hours or meter type) (Note: The meter type product has one flow meter and probe wire, but the time clock type doesn't have).

MODEL: F116A1/F116A3/F117A1/F117A3

● Four kinds of meter type can be selected (Suit for F116A3, F117A3)

Model	Name	Instruction
A-01	Meter Delayed	It will not regenerate although the available volume of treated water drops to zero (0). Regeneration will start until at the regeneration time.
A-02	Meter Immediate	Regenerate immediately when the available volume of treated water drops to zero(0).
A-03	Intelligent Meter Delayed	Meter Delayed Regeneration Type, by setting resin volume, raw water hardness, regeneration factor, the controller will calculate the system capacity. It will start regenerate when the available volume of treated water drops to zero(0) and reach the regeneration time.
A-04	Intelligent Meter Immediate	Meter Immediately Regeneration Type, by setting resin volume, raw water hardness, regeneration factor, the controller will calculate the system capacity. It will start regenerate when the available volume of treated water drops to zero(0).

● There are two kinds of regeneration modes for time clock type

When the program is set as time clock type by days (such as F116A1, F117A1, etc.), it can be changed to be by hours by dialing the red switch on main control board to "1" (Refer to the P14). Pointing to "ON" means the time clock type service by days. (Note: After dialing the switch, please restart the power).

● Interlock function

It has a function of interlock to realize only one valve in regeneration but the other valves are in service while several valves parallel in system. In multi-steps treatment systems such as RO pre-treatment, when several valves are in series, there is only one valve in regeneration or washing to ensure pass water all the times while different valves in regeneration or washing. (Application refers to Figure 3-9).

● Signal output

There is a signal output connector on the main control board. It is for controlling external wiring (refer to Figure 3-1 to Figure 3-8).

There are two kinds of output modes:

- b-01 Mode: Turn on start of regeneration and shut off at the end of regeneration;
- b-02 Mode: Signal available only at intervals of regeneration cycles and in service.

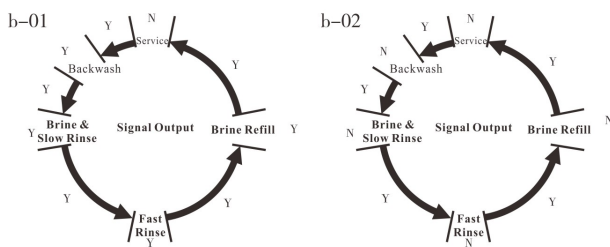

MODEL: F116A1/F116A3/F117A1/F117A3

● Remote handling input

This connector can receive external signal, used together with PLC, and computer etc. to control the valve. (Application refers to Figure3-11).

● Pressure relief output

The valve will cut off feeding water to drain line when it switches in regeneration cycles (Same as signal output b-02). Thus in some water treatment system, e.g. deep well, one booster pump was installed on the inlet to increase the system water feeding pressure, this cut-off will cause pressure on inlet rising too fast to damage the valve. Pressure Relief output can be used to avoid this problem. (Application refers to Figure 3-10)

● Maximum interval regeneration days

Under the situation of service reaching the setting days and the volume not yet, it could enter into regeneration process forcibly when current time is the same as regeneration time.

● All parameters can be modified

According to the water quality and usage, the parameters in the process can be adjusted.

1.3. Service Condition

Runxin valve should be used under the below conditions:

Items		Requirement
Working conditions	Water pressure	0.15MPa~0.6MPa
	Water temperature	5℃~50℃
Working environment	Environment temperature	5℃~50℃
	Relative humidity	≤95% (When temperature is 25℃)
Inlet water quality	Electrical facility	AC100~240V/50~60Hz
	Water turbidity	< 5FTU
	Water hardness	First Grade Na ⁺ < 6.5mmol/L; Second Grade Na ⁺ < 10mmol/L
	Free chlorine	< 0.1mg/L
	Iron ²⁺	< 0.3mg/L
	CODMn	< 2mg/L (O ₂)

In the above table, First Grade Na⁺ represents First Grade Na⁺ Exchanger. Second Grade Na⁺ represents Second Grade Na⁺ Exchanger.

● When the water turbidity exceeds the conditions, a filter should be installed on the inlet of control valve.

● When the water hardness exceeds the conditions, the outlet water hardness will hardly reach the requirement of boiler raw water (0.03 mmol/L). It is suggested to adopt second grade softener.

MODEL: F116A1/F116A3/F117A1/F117A3

1.4.Product Structure and Technical Parameters

A.Product dimension (The appearance is just for reference. It is subjected to the real product.)

F116A1 dimensions:

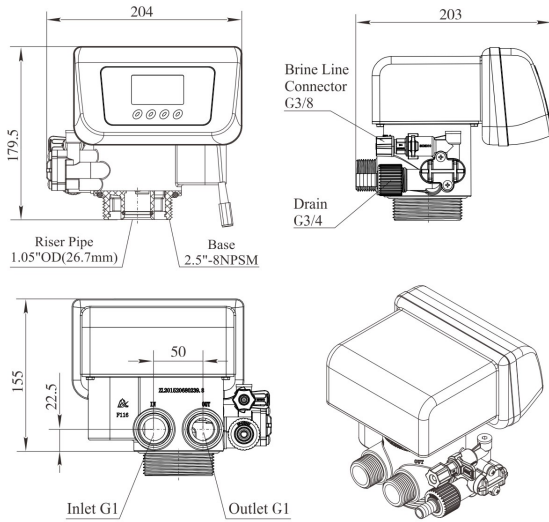

Note: F116A1 assemble a flow meter to be F116A3 meter type.

F117A1 dimensions:

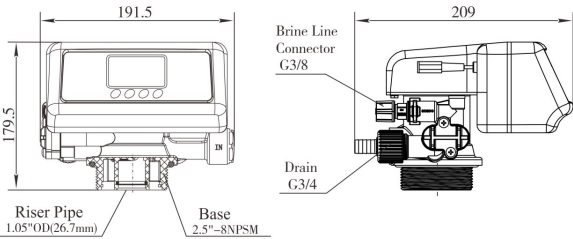

MODEL: F116A1/F116A3/F117A1/F117A3

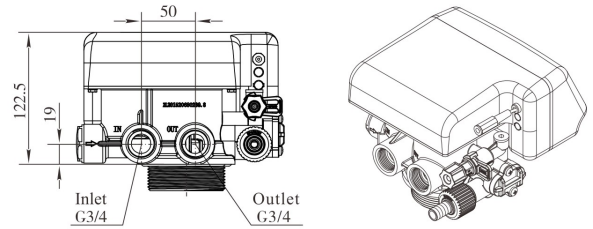

Note:F117A1 assemble a flow meter to be F117A3 meter type.

OD—Outer diameters, 1.05OD=26.7mm

B.Technical parameters

Transformer output: DC12V/1.5A

Model	Connection			Flow Rate m ³ /h @0.15MPa	Remark
	Inlet/ Outlet	Drain	Brine Line Connector		
F116A1	1" M	3/4" M	3/8" M	4	Down-flow, time clock type
F116A3					Down-flow, meter type
F117A1	3/4" F	3/4" M	3/8" M	2	Down-flow, time clock type
F117A3					Down-flow, meter type

Remark: M-Male thread, F-Female thread

1.5.Installation

●A. Installation notice

Before installation, read all those instructions completely. Then obtain all materials and tools needed for installation.

The installation of product, pipes and circuits should be accomplished by professional to ensure the product can operate normally.

Perform installation according to relevant pipeline regulations and the specifications of Water Inlet, Water Outlet, Drain Outlet, Brine Line Connector.

●B. Device location

- ①The filter or softener should be located close to drain.
- ②Ensure the unit is installed in enough space for operating and maintenance.
- ③Brine tank needs to be close to softener.
- ④The unit should be kept away the heater, and not be exposed outdoor. Sunshine or rain will cause the system damage.
- ⑤Avoid installing the system in circumstance of acid/alkaline, magnetic or strong vibration, because above factors will cause the system disorder.

⑥ Do not install the filter or softener, drain pipeline or overflow pipe in circumstance where temperature may drop below 5°C, or above 50°C.

⑦ Install the system in the place where with the minimum loss in case of water leakage.

C. Pipeline installation

① Install control valve

a. As the Figure 1-1 shows, select the riser pipe with 26.7mm OD, glue the riser pipe to the bottom strainer and put it into the resin tank, cut off the exceeding pipe out of tank top opening and make external rounding.

b. Fill the resin to the tank, and the height is accordance with the design code.

c. Install the top strainer to the valve.

d. Through the top strainer, insert the riser pipe into control valve and screw tight control valve.

Note:

- The length of riser pipe should be neither 2mm higher nor 5mm lower than tank top opening, and its top end should be rounded to avoid damaging of O-ring inside the valve.
- Avoid filling floccules substance together with resin to the resin tank.
- Avoid O-ring inside control valve falling out while rotating it on the tank.

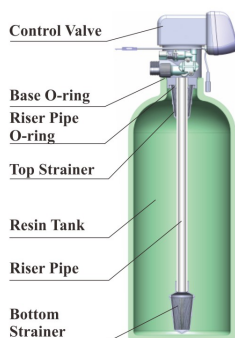

Figure 1-1

② Install animated connector

As Figure 1-2 shows, put the sealing ring into nut of animated connector, and screw in water inlet.

③ Install flow meter

As Figure 1-2 shows, put the sealing ring into nut of flow meter, screw in water outlet; insert the sensor into flow meter.

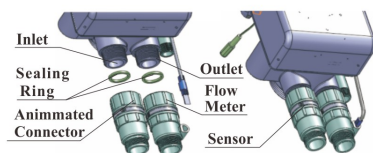

Figure 1-2

④ Pipeline connection

a. As Figure 1-3 shows, install a pressure gauge in water inlet.

b. Install valve A, valve B, valve C and valve D in the inlet, outlet and middle of the pipeline. The valve D is a sampling valve. (Or adopt F70A/F70C bypass valve).

c. Install a check valve on outlet.

d. Inlet pipeline should be in parallel with outlet pipeline. Support inlet and outlet pipeline with fixed holder.

Note:

- If the water outlet or water tank is installed higher than control valve or parallel interlock system with multi-outlets, a liquid level controller must be installed in brine tank or a check valve must be installed in the outlet. Or else, the water in water outlet or water tank will flow backwards into brine tank when backwash.
- If making a soldered copper installation, do all sweat soldering before connecting pipes to the valve. Torch heat will damage plastic parts.

- When turning threaded pipe fitting onto plastic fitting, do not use excessive force to make threads misaligned or broken valve.
- If the valve belongs to time clock type, there are no step ② and ③.

⑤ Install drain pipeline

a. As the Figure 1-4 shows, slide the drain hose connector into drain outlet.

b. Locate the drain hose well as the Figure 1-4 show.

Note:

- Control valve should be higher than drain outlet, and be better not far from the drain hose. (If the drain port is higher than control valve, a check valve should be installed on drain outlet. Or else, the drain water will flow back to outlet in brine refill.)
- Be sure not connect drain with sewer directly, and leave a certain space between them, avoid wastewater being absorbing to the water treatment equipment, such as showed in the Figure 1-4.

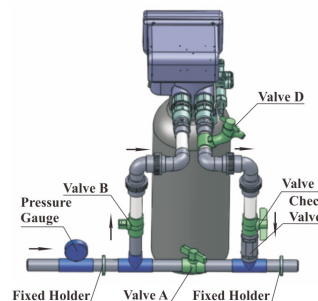

Figure 1-3

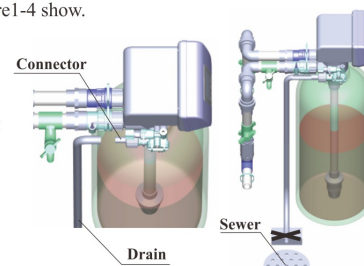

Figure 1-4

⑥ Connect brine tube

- As Figure 1-5 shows, slide 3/8" brine tube hose connector over end of brine tube.
- Insert tube bushing into the end of brine tube.
- Tighten brine draw hose connector onto brine line connector.
- Connect the other end of brine tube with the brine tank. (The liquid level controller and air-blocker should be installed in the brine tank.)

Note: The brine tube and drain pipeline should not be bended or plugged.

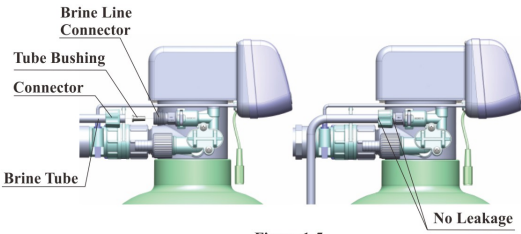
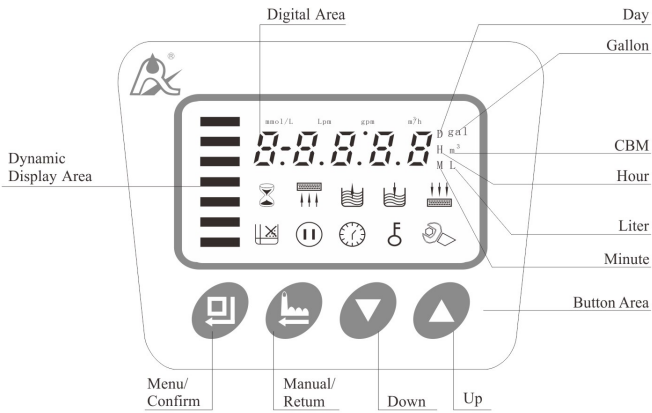

Figure 1-5

2. Basic Setting & Usage

2.1. The Function of PC Board



- Time of day indicator
 - Lights on, display the time of day.
 - "12:12" flashes, remind you to reset the time of day if electrical service interrupted 3 days more (If electrical service interrupted within 3 days, it doesn't need to reset the time.)
- Button lock indicator
 - Lights on, indicate the buttons are locked. At this moment, press any single button will not work (No operation in one minute, ⏻ will light on and lock the buttons.)
 - Solution: Press and hold both ⏻ and ⏮ for 5 seconds until the lights off.
- Program mode indicator
 - Lights on, enter program display mode. Use ⏻ or ⏮ to view all values.
 - Flashes and enter program set mode. Press ⏻ or ⏮ to adjust values.
- Menu/Confirm button
 - In menu model, press ⏻ and ⏻ lights on, then enter program display mode to view all values.
 - In program display mode, press ⏻, ⏻ flashes, enter program set mode, press ⏻ or ⏮ to adjust values.
 - Press ⏻ after all program are set, and then the voice "Di" means all setting are successful and return program display mode.
- Manual/Return button
 - Press ⏻ in any status, it can proceed to next step. (Example: After unlock the buttons, press ⏻ in service status, it will start regeneration cycles instantly if the outlet water is unqualified; Press ⏻ while it is in backwash status, it will end backwash and go to brine & slow rinse at once.)
 - Press ⏻ in program display mode, and it will return in service; Press ⏻ in program set mode, and it will return program display mode.
 - Press ⏻ while adjusting the value, then it will return to program display mode directly without saving value.
- Down ⏻ and Up ⏮
 - In program display mode, press ⏻ or ⏮ to view all values.
 - In program set mode, press ⏻ or ⏮ to adjust values.
 - Press and hold both ⏻ and ⏮ for 5 seconds to unlock the buttons.

MODEL: F116A1/F116A3/F117A1/F117A3

2.2. Basic Setting & Usage

A. Parameter specification

Function	Indicator	Factory Default	Parameter Set Range	Instruction
Time of Day		Random	00:00~23:59	Set the time of day when use ; ":" flashes.
Control Mode	A-01	A-01	A-01	Meter Delayed: Regenerate will not start although the available volume of treated water drops to zero (0). Regeneration will start until at the regeneration time.
			A-02	Meter Immediate: Regenerate immediately when the available volume of treated water drops to zero(0).
			A-03	Intelligent Meter Delayed: By setting resin volume, raw water hardness, regeneration factor, the controller will calculate the system capacity. Regeneration mode same as A-01.
			A-04	Intelligent Meter Delayed: By setting resin volume, raw water hardness, regeneration factor, the controller will calculate the system capacity. Regeneration mode same as A-02.
Unit Mode	HU-01	HU-01	01,02,03	01-m ³ ; 02-gal; 03-L
Service Days		1-03D	0~99 Days	Only for Time Clock Type, regeneration by days.
Service Hours		1-20H	0~99 Hours	Only for Time Clock Type, regeneration by hours.
Regeneration Time	02:00	02:00	00:00~23:59	Regeneration time; ":" lights on.
Resin Volume	20L	20L	5-500L	Resin volume in resin tank (L)
Raw Water Hardness	Yd1.2	1.2	0.1-9.9	Raw water hardness (mmol/L)
Exchange Factor	AL.65	0.65	0.30-0.99	Relate to the raw water hardness. When hardness is higher, the factor is smaller.
Water Treatment Capacity		10m ³	0~99.99m ³	Water treatment capacity in one circle(m ³)
Backwash Time		10min.	0~99:59	Backwash time (Minute)
Brine & Slow Rinse Time		60min.	0~99:59	Brine & Slow rinse time (Minute)
Fast Rinse Time		10min.	0~99:59	Fast rinse time (Minute)
Brine Refill Time		5min.	0~99:59	Brine refill time (Minute)

MODEL: F116A1/F116A3/F117A1/F117A3

Maximum Interval Regeneration Days	H-30	30	0~40	Regenerate at the regeneration time even though the available volume of treated water does not drop to zero (0).
Output Control Mode	b-01	01	01 or 02	b-01: Signal turn on when start of regeneration and shut off at the end of regeneration. (Connection refers to the Figure P3). b-02: Signal available only in intervals of regeneration cycles and in service. (Connection refers to the Figure P3).

B.Process display (take A-01 as an example)

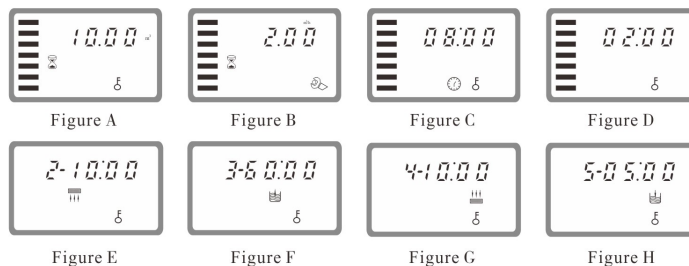

Illustration:

- In Service status, the figure shows A/B/C/D; In Backwash status, it shows figure E/C; In Brine & Slow Rinse status, it shows F/C; In Fast Rinse status, it shows figure G/C; In Brine Refill status, it shows figure H/C. In each status, every figure shows 15 seconds.
- Above displays are taking the meter type for example. For the time clock type, it shows the rest days or hours, such as 1-03D or 1-10H.
- The display screen will only show “-00-” when the electrical motor is running.
- The time of day figure flashes continuously, such as “12:12” flash, indicates long outage of power. It reminds to reset the time of day.
- The display will show the error code, such as “-E1-” when the system is in error.
- Working process: Service → Backwash → Brine & Slow Rinse → Fast Rinse → Brine Refill → Service.

C. Usage

After being accomplished installation, parameter setting and trial running by professional, the valve could be put into use. In order to ensure the quality of outlet water can reach the requirement, the user should complete the below works:

- ① Ensure that there is solid salt all the time in the brine tank in the course of using when this valve is used for softening. The brine tank should be added crystalline coarse salt only, at least 99.5% pure, forbidding use the small salt and iodized salt.
- ② Test the hardness of outlet water and raw water at regular time. When the outlet water hardness is unqualified, please press the [Enter] and the valve will temporarily regenerate again (It will not affect the original set operation cycle)
- ③ When the raw water hardness changes a lot, you can adjust the water treatment capacity as follow:

Press and hold both [Up] and [Down] for 5 seconds to unlock the buttons. Press [Enter], and the [Light] lights on, then press [Down], the digital area shows the control mode. If it shows A-01 or A-02, press [Down] three times, and the digital area will show the given water treatment capacity (If the control mode shows A-03 or A-04, then press [Down] four times, the digital area will show the raw water hardness); Press [Enter] again, [Light] and digital flash. Press [Up] or [Down] continuously, adjust the capacity value (Or water hardness). Press [Enter] and hear a sound “Di”, then finish the adjustment. Press [Enter] exit and turn back the service status.

For the estimation of water treatment capacity, you can refer to the professional application specification. When selecting A-03 or A-04 intelligent control mode, the controller will automatically calculate the water treatment capacity by setting raw water hardness, resin volume, and regeneration factor.

- ④ For A-01 or A-03 control mode (Delayed regeneration type), please pay attention to whether the time is current or not. If the time is not right, you can adjust as follow: After unlocking the buttons, press [Enter], the [Light] and [Light] lights on. Then press [Enter], the [Light] and hour value flash. Press [Up] or [Down] continuously, adjust the hour value; Press [Enter] again, [Light] and minute value flash. Press [Up] or [Down] continuously, adjust the minute value; Press [Enter] and hear a sound “Di”, then finish the adjustment. Press [Enter] exit and turn back the service status.

The regeneration parameters have been set when control valve left factory. Generally, it does not need to reset. If you want to enquiry and adjust the setting, you can refer to the professional application specifications.

3. Applications

3.1. Softener Flow Chart

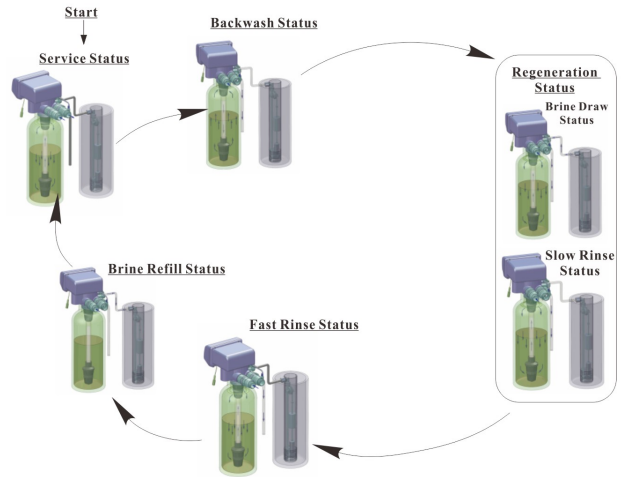

3.2. The Function and Connection of PC Board

Open the front cover of control valve, you will see the main control board and connection connectors as below:

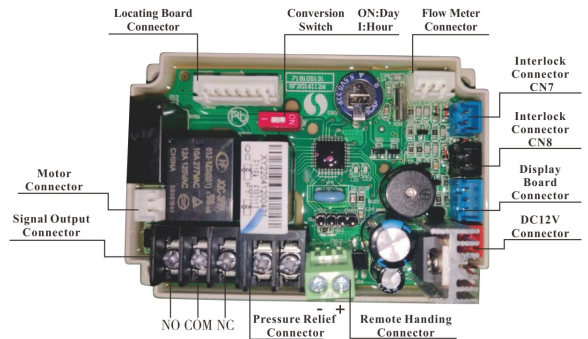

MODEL: F116A1/F116A3/F117A1/F117A3

The main functions on main control board:

Function	Application	Explanation
Signal output connector b-01	Outlet solenoid valve	Used in strict requirements regarding no hard water flowing from outlet or controlling the liquid level in water tank.
	Inlet pump	Increase pressure for regeneration or washing. Use the liquid level controller to control inlet pump to ensure there is water in tank.
Signal output connector b-02	Inlet solenoid valve or inlet pump	When inlet pressure is high, it needs to close water inlet to protect motor when valve is rotating.
Pressure relief connector	Control the inlet bypass to release pressure	Used for pump water supply. When valve is rotating, pressure relief connector opened to prevent pressure increasing rapidly.
Interlock connector	To ensure only one control valve regeneration or washing in system.	Use in RO Pre-treatment, water supply together but regeneration in turn. Second grade ion exchange equipment, etc.
Remote handling connector	Receipt signal to make the control valve rotate to next status.	It is used for on-line inspection system, connected with PC to realize automatically or remote controlling valve.

A.Signal output connector

1). Control outlet solenoid valve (set b-01)

① Solenoid valve on outlet controls the water level in brine tank

Instruction: If system requires no hard water flowing from outlet in regeneration cycle (Mainly for no hard water flows out when valve is switching or valve in backwash or brine drawing status), a solenoid valve could be installed on outlet, the wiring refers to Figure 3-1.

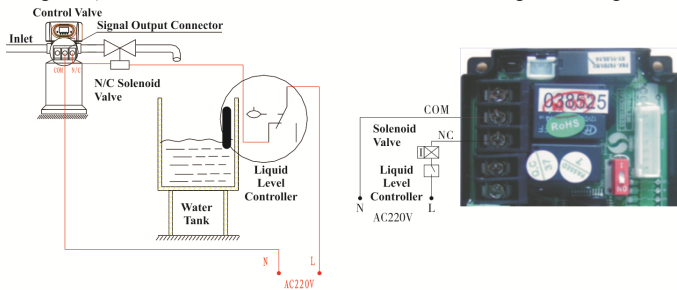

Figure 3-1 Wiring of Solenoid Valve on Outlet

MODEL: F116A1/F116A3/F117A1/F117A3

Function:

When valve is in service status, if soft water tank is short of water, solenoid valve will open to supply soft water, but if water tank has enough water, solenoid valve will close, so no soft water supplied.

When the valve in backwash status, there is no signal output. So, solenoid valve is closed, and now water flow into soft will be supplied into soft water tank.

② Control inlet solenoid valve (set b-02)

Instruction: When inlet pressure exceeds 0.6MPa, install a solenoid valve on inlet. Control mode is b-02. Pressure is relieved when valve switching, the wiring refers to Figure 3-2. As Figure 3-3 shows, it also can use the pressure relief connector to work.

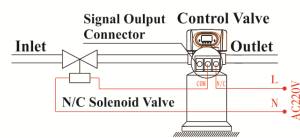

Figure 3-2 Wiring of Solenoid Valve on Inlet

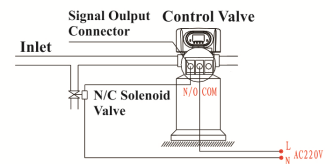

Figure 3-3 Wiring of Pressure Relief Connector

Function:

When inlet pressure is high, install a solenoid valve on inlet to ensure valve switching properly. When valve is exactly at status of Service, Backwash, Brine & Slow Rinse, Brine Refill and Fast Rinse, solenoid valve is open. When valve is switching, solenoid valve is closed, no water flows into valve to ensure valve switching properly. It could prevent the problem of mixing water and water hammer.

Use interlock cable to realize valves in parallel and series in same system which is suited for RO pre-treatment system or second grade Na⁺ system. The wiring refers to Figure 3-4.

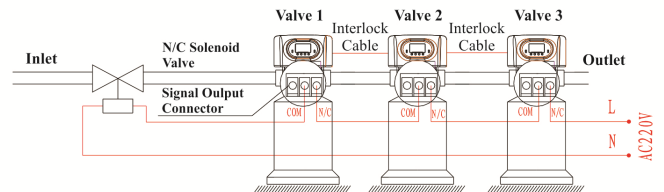

Figure 3-4 Wiring of Solenoid Valve on Inlet

2). Liquid level controller controls inlet pump (two-phase motor) (set b-01)

Instruction: For the system using well or middle-tank supplying water, switch of liquid level controller and valve together control pump opening or closing. The wiring refers to Figure 3-5.

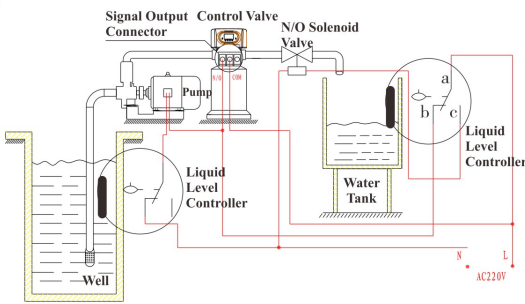

Figure 3-5 Wiring of Liquid Level Controller Controls Inlet Pump

Function:

When valve is in service status, if water tank is short of water, pump starts working; if not, the switch of liquid level controller is closed, so pump doesn't work.

When valve is in backwash or other regeneration status, no matter what is water condition in water tank, open the pump to make sure there is water on inlet. As there is no water flows out of outlet in regeneration cycle, it ensures no water fill into brine tank. A liquid level controller at the top opening of well or in middle water tank in RO system can protect pump from working without water in case of out of raw water.

3). Liquid level controller in water tank controls inlet pump (three-phase) (set b-01)

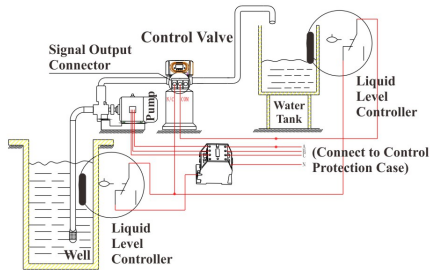

Figure 3-6 Wiring of Liquid Level Controller in Water Tank Controls Inlet Pump

4). Control inlet booster pump (set b-01 or b-02)

Instruction: If inlet water pressure is less than 0.15MPa, which makes rinse drawing difficult, a booster pump is suggested to be installed on inlet. Control mode b-01. When system in regeneration cycle, booster pump is open, the wiring refers to Figure 3-7. If the booster pump current is bigger than 5A, system needs to install a contactor, the wiring refers to Figure 3-8.

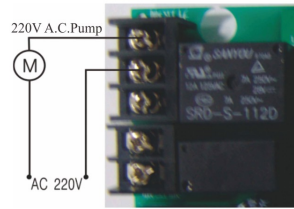

Figure 3-7 Wiring of Booster Pump on Inlet

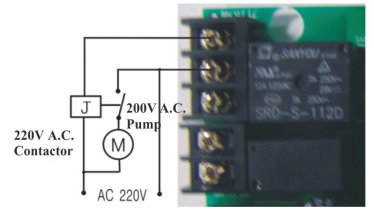

Figure 3-8 Wiring of Booster Pump on Inlet

B. Interlock

Instruction: In the parallel water treatment system, it ensures only one valve in regeneration or washing status and (n-1) valves in service, that is, realizing the function of supplying water simultaneously and regenerating individually.

In the series water treatment system (Second grade Na⁺ Exchanger or RO pre-treatment system), it ensures only one valve in regeneration or washing status and there is/are water(s) in service. The wiring refers to Figure 3-9.

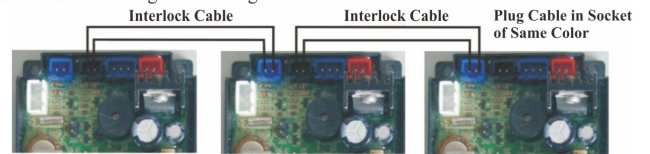

Figure 3-9 Network System Wiring with Interlock Cable

Note: Use interlock cable to connect the black socket of one valve with the blue socket of another valve in series.

One system with several valves, if interlock cable is disconnected, the system is divided into two individual systems.

C. Pressure relief output

In adopt inlet booster pump or well water supply systems, valve switching will increase the system water feeding pressure, the motor can't rotate. Installing the solenoid valve in the inlet pipeline, connecting with the drain. When the valve switching, the pressure relief solenoid valve opens, the water flows to the drain. Avoiding the system closed, which will cause the inlet pressure rising too fast to damage the valve. The wiring refers to Figure 3-10.

MODEL: F116A1/F116A3/F117A1/F117A3

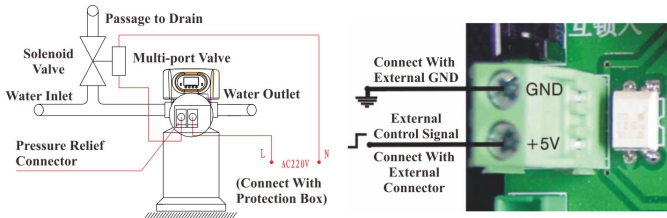

Figure 3-10 Wiring of Pressure Relief Output

D. Remote handling connector

When the valve is used to make pure water or other system that can be monitored online or connected to a PC, etc., when the conductivity or other parameters reach the set value or the PC sends a signal and needs system regeneration, it can provide a signal to remote handling connector of main control board by the signal line, which can make the valve regenerate immediately. The connector receiving the signal is equivalent to pressing the manual button. The wiring refers to Figure 3-11:

E. Interlock system

2 or more than 2 valves are interlocked connecting in one system and all valves are in service but regenerate individually. The wiring refers to Figure 3-12.

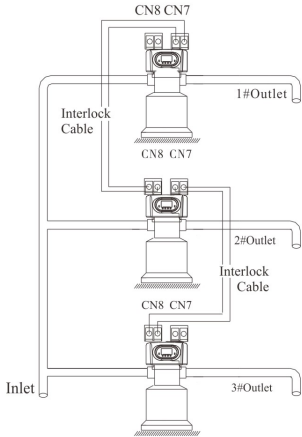

Figure 3-12 Interlock System

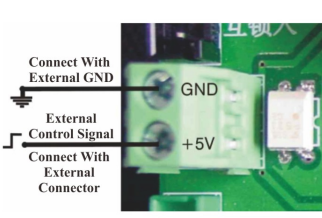

Figure 3-11 Wiring of Remote Input

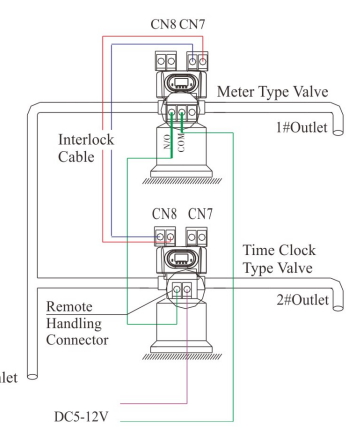

Figure 3-13 Series System

MODEL: F116A1/F116A3/F117A1/F117A3

F. Series system

This is a 2 or more than 2 valves system, all in service, with one flow meter for the entire system. For the time type valve, the regeneration time should be set and adjusted to the Max; for the meter type valve, connect its signal output connector with the remote handling connector of the time clock type valve. That can realize the function of supplying water simultaneously and regenerating orderly. The wiring refers to Figure 3-13.

3.3. System Configuration and Flow Rate Curve

A. Product configuration

① Product configuration with tank, resin volume, brine tank and injector.

Tank Size (mm)	Resin Volume (L)	Flow Rate (t/h)	Brine Tank Size (mm)	The Minimum Salt Consumption for Regeneration (Kg)	Injector Model	Control Valve Model
φ 180 × 1130	16	0.5	φ 250 × 520	2.40	6803	F117
φ 205 × 1300	25	0.7	φ 390 × 810	4.00		
φ 255 × 1390	40	1.2	φ 390 × 810	6.00	6804	
φ 300 × 1650	60	1.8	φ 450 × 940	9.00	6807	
φ 355 × 1650	100	2.5	φ 500 × 1060	15.00	6806	F116
φ 255 × 1390	40	1.2	φ 390 × 810	6.00		
φ 300 × 1650	60	1.8	φ 450 × 940	9.50	6809	
φ 355 × 1650	100	2.5	φ 500 × 1060	15.00	6808	
φ 400 × 1650	120	3.5	φ 500 × 1160	18.00		
φ 450 × 1650	150	4.5	φ 500 × 1160	22.50	6809	

Note: The flow rate calculation is based on linear velocity 25m/h; the minimum salt consumption for regeneration calculation is based on salt consumption 150g / L (Resin).

B. Flow rate characteristic

1). Pressure-flow rate curve

F117:

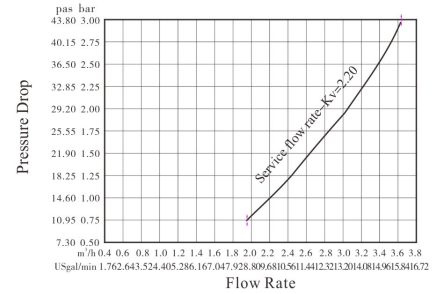

MODEL: F116A1/F116A3/F117A1/F117A3

F116:

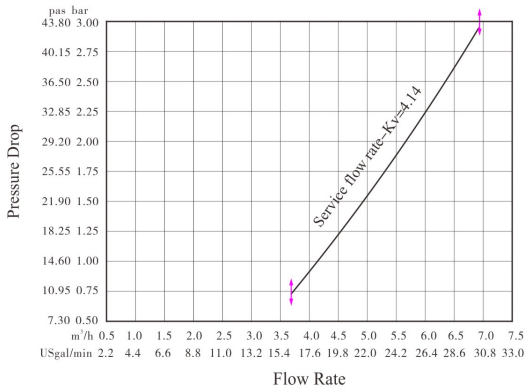

2) Injector Parameter Table

Inlet Pressure	Draw Rate/Slow Rinse Rate (L/M)					
	F117			F116		
MPa	6803 Yellow	6804 Blue	6807 Purple	6806 Black	6808 Red	6809 Green
0.15	1.95	2.37	3.08	3.73	4.78	5.77
0.20	2.28	2.70	3.52	4.27	5.58	6.68
0.25	2.52	3.02	3.88	4.78	6.28	7.37
0.30	2.75	3.33	4.27	5.27	6.80	8.10
0.35	2.95	3.55	4.63	5.67	7.37	9.70
0.40	3.15	3.75	4.92	6.07	7.65	9.18

3) Configuration for Standard Injector, Brine Line Flow Control and Drain Line Flow Control

Tank Dia mm	Injector Model	Injector Color	Draw Rate	Slow Rinse Rate	BLFC Optional	DLFC Model	Back-wash/ Fast Rinse	Control Valve Model
			L/m	L/m			L/m	
175~200	6803	Yellow	2.75	1.66	8468076, 8468075, 8468057, 8468056, 8468052, 8468053(Standard).	8468042	7.33	F117

MODEL: F116A1/F116A3/F117A1/F117A3

225~250	6804	Blue	3.33	2.18	8468076, 8468075, 8468057, 8468056, 8468052, 8468053(Standard).	8468060	8.33	F117
300~350	6807	Purple	4.27	3.03	8468076, 8468075, 8468057, 8468056, 8468052, 8468053, 8468054, 8468055 (Standard).	8468062	16.83	
250~300	6806	Black	5.27	3.31	8468076, 8468075, 8468057, 8468056, 8468052, 8468053, 8468054(Standard).	8468077	19.00	F116
325~350	6808	Red	6.80	4.28	8468076, 8468075, 8468057, 8468056, 8468052, 8468053, 8468054, 8468055 (Standard).	8468062	24.83	
400~450	6809	Green	8.10	5.23	8468076, 8468075, 8468057, 8468056, 8468052, 8468053, 8468054, 8468055 (Standard).	No DLFC	31.33	

Note: Above data for the product configurations and relevant characteristics are only for reference. When put into practice, it is subject to different requirements of raw water hardness and application.

4) Configuration for BLFC

Flow Rate	Part Number	8468076	8468075	8468057	8468056	8468052	8468053	8468054	8468055
	L/m		0.38	0.64	0.98	1.21	1.66	2.14	5.14
gal/min		0.10	0.17	0.26	0.32	0.44	0.83	1.36	1.55

3.4. Parameter Settlement

① Service Time T1

Water treatment capacity:

$$Q = V_r \times K \div Y_p \text{ (m}^3\text{)}$$

- Hardness of inlet water (mmol/L)
- Exchange factor (mmol/L) 400~1000.
- Down-flow regeneration, take 400~750;
- Up-flow regeneration, take 450~1000.
- If the inlet water hardness is higher, the factor is smaller.
- Resin volume (m³)

By hours: $T1 = Q \div Q_h \text{ (Hour)}$

- Average water consumption per hour (m³/h)
- Water treatment capacity (m³)

MODEL: F116A1/F116A3/F117A1/F117A3

By days: $T1=Q \div Q_d$ (Day)

Average water consumption per day (m^3/d)
Water treatment capacity (m^3)

② Backwash Time T2

Generally, it is suggested to set 10~15 minutes. The higher the turbidity is, the longer backwash time can be set. However, if the turbidity is more than 5FTU, it should be better to install a filter in front of the exchanger.

③ Brine & Slow Rinse Time T3

$T3=(40 \sim 50) H_r$ (min.)

Generally, $T3=45H_r$ (min.)

In this formula, H_r — The height of resin in exchange tank (m)

④ Brine Refill Time T4

Down-flow regeneration: $T4 = 0.45 \times V_r \div$ Brine refill speed (min.)

Up-flow regeneration: $T4 = 0.34 \times V_r \div$ Brine refill speed (min.)

In this formula: V_r — Resin volume (m^3)

The Brine refill speed is related to inlet water pressure. It is suggested to be 1~2 minutes longer than the calculated brine refilling time to make sure there is enough water in tank. (The brine tank should be equipped with liquid level controller)

⑤ Fast Rinse Time T5

$T5=12 \times H_r$ (min.)

Generally, the water for fast rinse is 3~6 times of resin volume. It is suggested to be set 10~16 minutes, but it should meet the requirements of qualified outlet water.

⑥ Exchange Factor

Exchange factor $=E/(k \times 1000)$

In this formula, E—Resin working exchange capability (mol/m^3), it is related to the quality of resin. Down-flow regeneration, take 800~900. Up-flow regeneration, take 900~1200.

K—Security factor, always take 1.2~2. It is related to the hardness of inlet water: the higher the hardness is, the bigger the K is.

⑦ Regeneration Time

The whole cycle for regeneration is about two hours. Please try to set up the regeneration time when you don't need to use water according .

The calculation of parameters for each step is only for reference, the actual proper time will be determined after adjusting by water exchanger supplier. This calculation procedure of softener is only for industrial application; it is not suitable for small softener in residential application.

MODEL: F116A1/F116A3/F117A1/F117A3

3.5. Parameter Enquiry and Setting

3.5.1. Parameter Enquiry

When δ lights on, press and hold both Δ and ∇ for 5 seconds to unlock the button; then press \square and \odot lights on, enter to program display mode; press Δ or ∇ to view each value according to below process. (Press \ominus exit and turn back to service status)

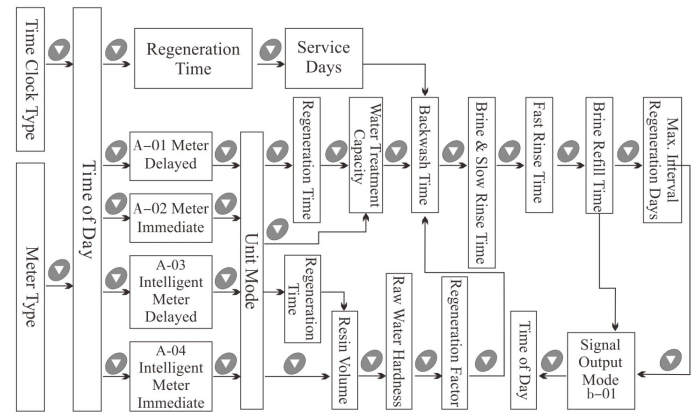

3.5.2. Parameter Setting

In program display mode, press \square and enter into program set mode. Press Δ or ∇ to adjust the value.

3.5.3. The Steps of Parameter Setting

Items	Process Steps	Symbol
Time of Day	When time of day "12:12" continuously flash, it reminds to reset; 1. Press \square to enter into program display mode; both \odot and δ symbol light on, ":" flashes; Press \square to set "time of day" mode, both \odot and hour value flash, through Δ or ∇ to adjust the hour value; 2. Press \square again, both \odot and minute value flash, through Δ or ∇ to adjust the minute value; 3. Press \square and hear a sound "Di", then finish adjustment, press \ominus to turn back.	
Control Model	1. In program display status, press \square and enter into program set mode, \odot and 01 value flash; 2. Press Δ or ∇ , set the value to be A-01/02/03/04 control mode; 3. Press \square and hear a sound "Di", then finish adjustment, press \ominus to turn back.	

MODEL: F116A1/F116A3/F117A1/F117A3

Unit Mode	1. In unit mode display status, press and enter into program set mode. and 01 value flash; 2. Press or , and choose the unit from the m ³ /L/gal; 3. Press and hear a sound "Di", then finish adjustment, press to turn back.	
Regeneration Time	1. In regeneration time display status, press and enter into program set mode. Shows "02:00", and 02 flash; Press or to adjust the hour value; 2. Press again, and 00 flash, press or to adjust the minute value; 3. Press and hear a sound "Di", then finish adjustment, press to turn back.	
Water Treatment Capacity	1. In water treatment capacity display status, it shows and 10.00. Press and enter into program set mode. and 10.00 flash; 2. Press or to adjust the water treatment capacity value (m ³); 3. Press and hear a sound "Di", then finish adjustment, press to turn back.	
Resin Volume	1. In resin volume display status, it shows 100L. Press and enter into program set mode. and 100 value flash; 2. Press or to adjust the volume value (L); 3. Press and hear a sound "Di", then finish adjustment, press to turn back.	
Raw Water Hardness	1. In raw water hardness display status, it shows yd1.2. Press and enter into program set mode. and 1.2 value flash; 2. Press or to adjust the hardness value (mmol/L); 3. Press and hear a sound "Di", then finish adjustment, press to turn back.	
Exchange Factor	1. In exchange factor display status, it shows AL.55. Press and enter into program set mode. and 55 flash; 2. Press or to adjust the exchange factor value; 3. Press and hear a sound "Di", then finish adjustment, press to turn back.	
Backwash Time	1. In backwash time display status, it shows and 2-10:00. Press and enter into program set mode. and 10:00 flash; 2. Press or to adjust the backwash time; 3. Press and hear a sound "Di", then finish adjustment, press to turn back.	
Brine & Slow Rinse Time	1. In brine & slow rinse time display status, it shows and 3-60:00. Press and enter into program set mode. and 60:00 flash; 2. Press or to adjust the brine time (minute); 3. Press and hear a sound "Di", then finish adjustment, press to turn back.	

MODEL: F116A1/F116A3/F117A1/F117A3

Fast Rinse Time	1. In fast rinse time display status, it shows and 4-10:00. Press and enter into program set mode. and 10:00 flash; 2. Press or to adjust the fast rinse time (minute); 3. Press and hear a sound "Di", then finish adjustment, press to turn back.	
Brine Refill Time	1. In brine refill time display status, it shows and 5-05:00. Press and enter into program set mode. and 05:00 flash; 2. Press or to modify the brine refill time (minute); 3. Press and hear a sound "Di", then finish adjustment, press to turn back.	
Maximum Interval Regeneration Days	1. In maximum interval regeneration days display status, it shows H-30. Press and enter into program set mode. and 30 flash; 2. Press or to adjust the interval regeneration days (day); 3. Press and hear a sound "Di", then finish adjustment.	
Signal Output Mode	1. In signal output mode display status, it shows b-01. Press and enter into program set mode. and 01 flash; 2. Press or to adjust the output mode (b-02); 3. Press and hear a sound "Di", then finish adjustment, press to turn back.	

For example, the fast rinse time of a softener is 12 minutes. After regenerating, the chloridion in the outlet water is always higher than normal, indicating that there is not enough time for fast rinse. If you want to set the time to 15 minutes, the modification steps as follows:



- ① Press and hold both and to unlock the button. (lights off);
- ② Press , and lights on;
- ③ Press or continuously until lights on. Then the digital area shows: 4-12:00M;
- ④ Press , and 12 flash;
- ⑤ Press continuously until 12 changed to 15;
- ⑥ Press , there is a sound "Di" and the figure stop flashing; the program back to program display mode.
- ⑦ If you want to adjust other parameters, you can repeat the steps from ② to ⑥; If you don't, press and exit from the program display mode, the display will show the current service status.



3.6. Trial Running



After installing the multi-functional flow control valve on the resin tank with the connected pipes, as well as setting up the relevant parameters, please conduct the trial running as follows:



A. Close inlet/outlet valve B and valve C, open bypass valve A, clean the impurity in the pipe, and then close the bypass valve A. (As Figure 1-3 shows)



B. Add calculated water to the brine tank and adjust the air check valve. Then add solid salt to the brine tank and dissolve the salt as much as possible.

C. Switch on power. Press  and enter into the backwash status; when  lights on, slowly open the inlet valve B to 1/4 position, making the water flows into the resin tank; you can hear the sound of air-out from the drain pipeline. After all air is out of pipeline, then open inlet valve B completely and clean the impurity in the resin tank until the outlet water is clean. It will take 8~10 minutes to finish the whole process.

D. Press , and turn the status from backwash to brine & slow rinse; when  lights on and enter in the process of brine & slow rinse. The air check valve close when control valve finished sucking brine, then slow rinse starts to work. It is about 60~65 minutes for whole process.

E. Press , and turn the status from brine & slow rinse to fast rinse status. When  lights on and starts to fast rinse. After 10~15 minutes, take out some outlet water for testing: if the water hardness reach the requirement, and the chloridion in the water is almost the same compared with the inlet water, then go to the next step.

F. Press , and turn the status from fast rinse to brine refill status.  lights on and it indicates the brine tank is being refilled with water to the required level. It takes about 5~6 minutes, then add solid salt to the brine tank.

G. Press , finish brine, make the control valve return to service status;  lights on and starts running.

Note:

● When the control valve enters into the regeneration status, all programs can be finished automatically according to the setting time; if you want one of steps to be terminated early, you can press  .

● If water inflows too fast, the media in tank will be damaged. When water inflows slowly, there is a sound of air emptying from drain pipeline.

● After changing resin, please empty air in the resin according to above step C.

● In the process of trial running, please check the water situation in all status, ensuring there are no resin leakage.

● The time for backwash, brine & slow rinse, fast rinse and brine refill status can be set and executed according to the calculation in the formula or suggested from the control valve suppliers.

3.7. Trouble-Shooting

A. Control Valve Fault

Problem	Cause	Correction
1. Softener fails to regenerate.	A. Electrical service to unit has been interrupted. B. Regeneration time set incorrect. C. Controller damaged. D. Motor fails to work.	A. Assure permanent electrical service (Check fuse, plug, pull switch and so on). B. Reset regeneration time. C. Replace controller. D. Replace motor.
2. Regeneration time is not correct.	A. Time of day does set correctly. B. Power failure more than 3 days.	A. Check program and reset time of day. B. Reset time of day.
3. Softener supply hard water.	A. Bypass valve is open or leaking. B. No salt in brine tank. C. Injector plugged. D. Insufficient water flows into brine tank. E. O-ring on riser pipe leaks. F. Internal valve leaks. G. Regeneration cycles not correct or raw water quality deterioration. H. Shortage of resin. I. Bad quality of raw water or impeller blocked.	A. Close or repair bypass valve. B. Make sure there is solid salt in the brine tank. C. Change or clean injector. D. Check brine tank refill time. E. Make sure riser pipe is not cracked. F. Check o-ring and tube pilot. G. Check and repair valve body. H. Add resin to mineral tank and check whether resin leaks. I. Reduce the inlet turbidity, clean or replace flow meter.
4. Softener fails to draw brine.	A. Inlet pressure is too low. B. Brine line plugged. C. Brine line leaks D. Injector plugged or damaged. E. Interior of valve leaks. F. Drain line plugged. G. Sizes of injector and DLFC are not matched with tank.	A. Increase inlet pressure. B. Check and clean brine line. C. Clean brine line. D. Clean or replace injector. E. Repair or replace valve body. F. Check drain line. G. Select correct injector and DLFC according to the instruction requirements.
5. Unit used too much salt.	A. Improper salt setting. B. Excessive water in brine tank.	A. Check salt usage and salt setting. B. See problem no.6.
6. Excessive water in brine tank.	A. Overlong brine refill time. B. Excess water left after brine. C. Foreign material in brine valve. D. Not install liquid level controller and power failure in brine status. E. Brine refill is uncontrolled.	A. Reset correct brine refill time. B. Check the injector and make sure no stuff in the brine pipe. C. Clean liquid level controller and brine line. D. Stop water supplying and restart or installs liquid level controller in salt tank when power restored. E. Repair or replace liquid level controller.

MODEL: F116A1/F116A3/F117A1/F117A3

7. Pressure lost or the pipe rusted.	A. Iron scale in the water supply pipe. B. Iron scale accumulated in the softener. C. Fouled resin bed. D. Too much iron in the raw water.	A. Clean the water supply pipe. B. Clean valve and add resin cleaning chemical, increase frequency of regeneration. C. Check backwash, brine draw and brine tank refill. Increase frequency of regeneration and backwash time. D. Iron removal equipment is required to install before softening.
8. Resin discharged through drain pipe	A. Air in water system. B. Strainer is broken. C. Large drain flow rate when backwash.	A. Empty the air from the system. B. Replace new strainer. C. Check and adjust proper drain rate.
9. Control valve cycle continuously.	A. Locating signal wire breakdown. B. Controller is faulty. C. Foreign material stuck the driving gear. D. Time of regeneration steps were set to zero.	A. Check and connect locating signal wire. B. Replace controller. C. Take out foreign material. D. Check program setting and reset.
10. Drain flows continuously.	A. Interior of valve leaks. B. Power off when in backwash or fast rinse.	A. Check and repair valve body or replace it. B. Adjust valve to service status or turn off bypass valve and restart when electricity supply.
11. Interrupted or irregular draw.	A. Water pressure is too low or not stable. B. Injector is plugged or damaged. C. Air in resin tank. D. Floccules in resin tank during up-flow regeneration.	A. Increase water pressure. B. Clean or replace injector. C. Check and find the reason. D. Clean the floccules in resin tank.
12. Water flows out from drain or brine pipe after regeneration.	A. Foreign material in valve which makes valve can't be closed completely. B. Hard water mixed in valve body. C. Water pressure is too high which results in valve not getting the right status. D. Under the backwash status, the outlet line and brine line are connected.	A. Clean foreign material in valve body. B. Change valve core or sealing ring. C. Reduce water pressure or use pressure release function. D. Install a check valve, solenoid valve in front of the outlet or install a liquid level controller in the brine tank.
13. Salt water in outflow pipe	A. Foreign material in injector or injector fails to work. B. Brine valve can't be shut-off. C. Fast rinse time is too short.	A. Clean and repair injector. B. Repair brine valve and clean it. C. Extend fast rinse time.
14. Water capacity decreases.	A. Regenerate not properly. B. Fouled resin bed. C. Salt setting is not proper. D. Softener setting is not proper. E. Raw water quality deteriorated. F. Impeller has already gotten stuck.	A. Regenerate according to the right way. B. Increase backwash flow rate and times, clean or change resin. C. Reset the appropriate amount of salt. D. According to the test of outlet water, recount and reset. E. Regenerate by manual temporarily, then reset regeneration cycle. F. Disassemble flow meter and clean it or replace it with a new flow meter.

MODEL: F116A1/F116A3/F117A1/F117A3

B. Controller Fault

Problem	Cause	Correction
1. All indicators display on display board.	A. Wiring of display board with control board fails to work. B. Control board is damaged. C. Transformer damaged. D. Electrical service is not stable.	A. Check and replace the wiring. B. Replace control board. C. Check and replace transformer. D. Check and adjust electrical service.
2. No display on display board.	A. Wiring of display board with control board fails to work. B. display board damaged. C. Control board damaged. D. Electricity is interrupted.	A. Check and replace wiring. B. Replace display board C. Replace control board. D. Check electricity.
3.E1 Flashes	A. Wiring of locating board with control board fails to work. B. Locating board damaged. C. Mechanical driven failure. D. Control board damaged. E. Wiring of motor with control board is fault. F. Motor damaged.	A. Replace wiring. B. Replace locating board. C. Check and repair mechanical part. D. Replace control board. E. Replace wiring. F. Replace motor.
4.E2 Flashes	A. Hall component on locating board damaged. B. Wiring of locating board with control board fails to work. C. Control board damaged.	A. Replace locating board. B. Replace wiring. C. Replace control board.
5.E3 or E4 Flashes	A. Control board damaged.	A. Replace control board.

MODEL: F116A1/F116A3/F117A1/F117A3

3.8. Assembly & Parts

Flow Meter Connector & Animated Connector

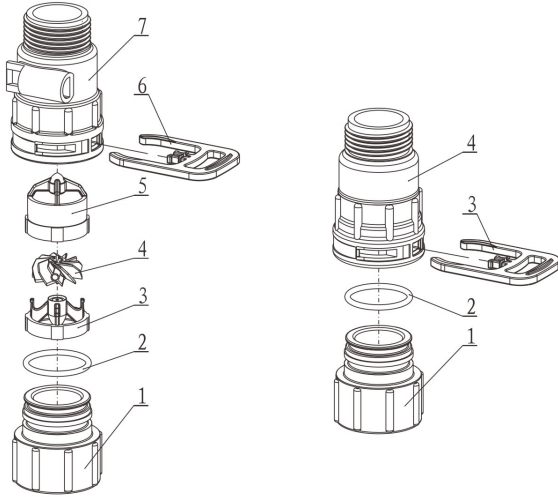

5447018 Flow Meter

5457002 Animated Connector

5447018 Flow Meter				5457002 Animated Connector			
Item No.	Description	Part No.	Quantity	Item No.	Description	Part No.	Quantity
1	Animated Nut	8945001	1	1	Animated Nut	8945001	1
2	O-ring	8378081	1	2	O-ring	8378081	1
3	Impeller Supporter	5115022	1	3	Clip	8270004	1
4	Impeller	5436010	1	4	Connector	8458038	1
5	Impeller Supporter	5115021	1				
6	Clip	8270004	1				
7	Shell	8002001	1				

MODEL: F116A1/F116A3/F117A1/F117A3

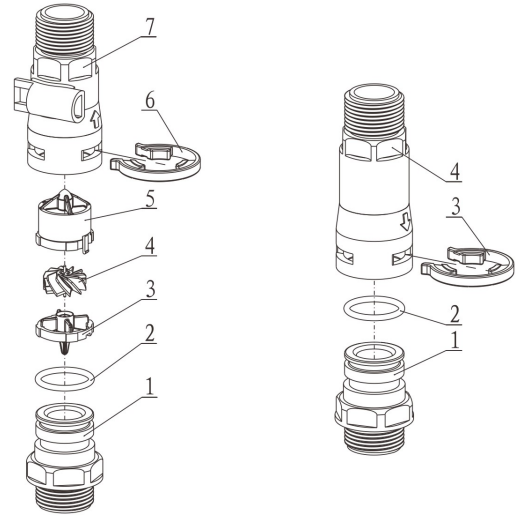

5447020 Flow Meter

5457003 Animated Connector

5447020 Flow Mete				5457003 Animated Connector			
Item No.	Description	Part No.	Quantity	Item No.	Description	Part No.	Quantity
1	Connector	8458014	1	1	Connector	8458014	1
2	O-ring	8378064	1	2	O-ring	8378064	1
3	Impeller Supporter	5115023	1	3	Clip	8270005	1
4	Impeller	5436013	1	4	Connector	8458039	1
5	Impeller Supporter	5115024	1				
6	Clip	8270005	1				
7	Shell	8002006	1				

MODEL: F116A1/F116A3/F117A1/F117A3

F116A3 Valve Body Assembly

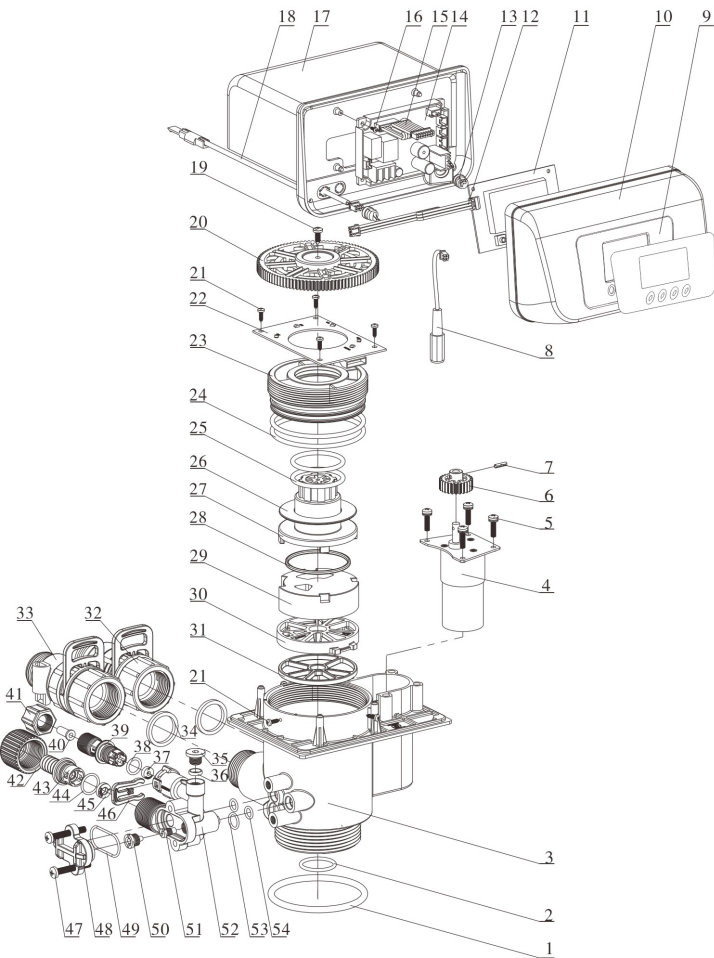

MODEL: F116A1/F116A3/F117A1/F117A3

F116A3 Valve Body Components (There is no item No. 18, 32, 33 for F116A1)

Item No.	Description	Part No.	Quantity	Item No.	Description	Part No.	Quantity
1	O-ring 73×5.3	8378143	1	28	Moving Seal Ring	8370001	1
2	O-ring 25.8×2.65	8378078	1	29	Moving Disk	8459078	1
3	Valve Body (ABS+GF10)	5022104	1	30	Fixed Disk	8469079	1
	Valve Body (PPO+GF20)	5022105		31	Seal Ring	8370111	1
4	Motor	6158073	1	32	Animated Connector	5457002	2
5	Screw, Cross ST3.9×16	8909044	4	33	Flow Meter	5447018	1
6	Small Gear, Motor	8241003	1	34	Seal Ring	8371001	2
7	Pin	8993003	1	35	Plug	8323002	1
8	Wire for Power	5513001	1	36	Seal Ring	8370012	1
9	Label	8865002	1	37	Brine Line Flow Control	8468055	1
10	Front Cover	8300001	1	38	O-ring 11×2	8378169	1
11	Display Board	6381003	1	39	Connector	8458068	1
12	Wire for Display Board	5512001	1	40	Tube	8457004	1
13	Cable Clip	8126004	2	41	Hexagonal Nut	8940001	1
14	Control Board	6382113	1	42	Animated Nut	8945025	1
15	Wire for Locating Board	5511001	1	43	Connector	8458068	1
16	Screw, Cross ST2.2×6.5	8909004	2	44	O-ring 15×1.8	8378179	1
17	Dust Cover	8005006	1	45	Drain Line Flow Control	/	1
18	Probe Wire	6386014	1	46	Clip	8270010	1
19	Screw, Cross ST3.9×13	8909013	1	47	Screw, Cross M5×35	8902017	2
20	Big Gear, Driven	5241023	1	48	Cover, Injector	8315001	1
21	Screw, Cross ST2.9×9.5	8909008	6	49	O-ring 30×1.8	8378025	1
22	Locating Board	6380044	1	50	Nozzle, Injector	8454009	1
23	Fitting Nut	8092004	1	51	Throat, Injector	8467009	1
24	O-ring 73×3.55	8378128	2	52	Injector Body	8008010	1
25	O-ring 38.7×3.55	8378184	2	53	O-ring 10.82×1.78	8378012	1
26	Anti-friction Washer	8216004	1	54	O-ring 7.5×1.8	8378016	2
27	Shaft	8258004	1				

MODEL: F116A1/F116A3/F117A1/F117A3

F117A3 Valve Body Assembly

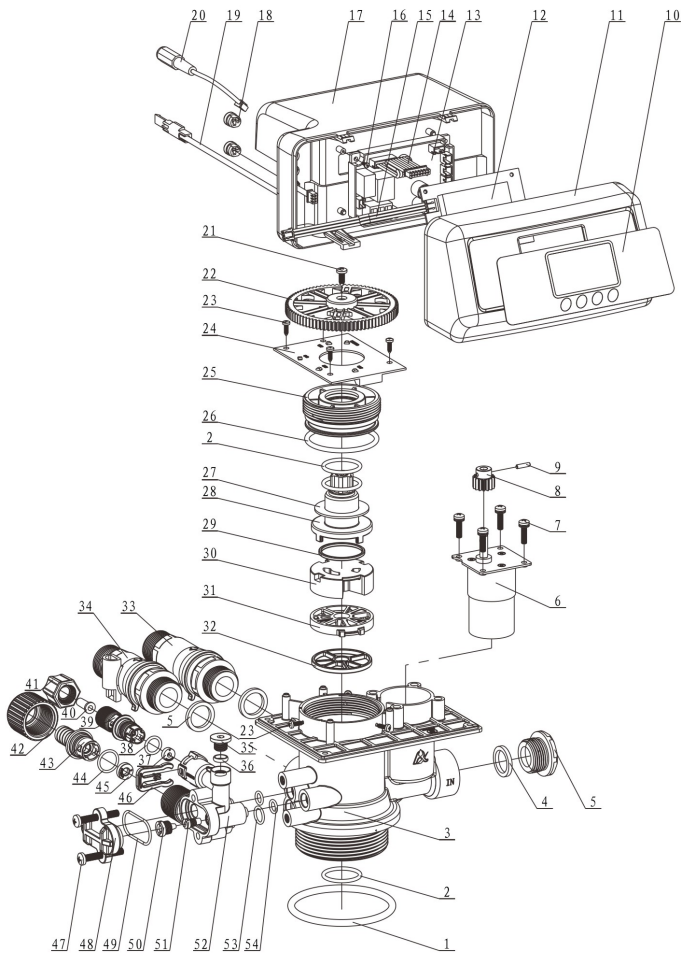

MODEL: F116A1/F116A3/F117A1/F117A3

F117A3 Valve Body Components (There is no item No. 19, 33, 34 for F117A1)

Item No.	Description	Part No.	Quantity	Item No.	Description	Part No.	Quantity
1	O-ring 73×5.3	8378143	1	27	Anti-friction Washer	8216010	1
2	O-ring 25.8×2.65	8378078	1	28	Shaft	8258009	1
3	Valve Body (ABS+GF10)	5022106	1	29	Moving Seal Ring	8370053	1
	Valve Body (PPO+GF20)	5022107		30	Moving Disk	8459079	1
4	Seal Washer	8371019	3	31	Fixed Disk	8469080	1
5	Plug	8323005	1	32	Seal Ring	8370112	1
6	Motor	6158006	1	33	Animated Connector	5457003	1
7	Screw, Cross ST3.9×16	8909044	4	34	Flow Meter	5447020	1
8	Small Gear, Motor	8241010	1	35	Plug	8323002	1
9	Pin	8993003	1	36	Seal Ring	8370012	1
10	Label	8865004	1	37	Brine Line Flow Control	8468055	1
11	Front Cover	8300004	1	38	O-ring 11×2	8378169	1
12	Display Board	6381003	1	39	Connector	8458068	1
13	Control Board	6382113	1	40	Tube	8457004	1
14	Wire for Locating Board	5511001	1	41	Hexagonal Nut	8940001	1
15	Wire for Display Board	5512001	1	42	Animated Connector	8945025	1
16	Screw, Cross ST2.2×6.5	8909004	2	43	Connector	8458064	1
17	Dust Cover	8005005	1	44	O-ring 15×1.8	8378179	1
18	Cable Clip	8126004	2	45	Drain Line Flow Control	8468062	1
19	Probe Wire	6386014	1	46	Clip	8270010	1
20	Wire for Power	5513001	1	47	Screw, Cross M5×35	8902017	2
21	Screw, Cross ST3.9×13	8909013	1	48	Cover, Injector	8315001	1
22	Big Gear, Driven	5241024	1	49	O-ring 30×1.8	8378025	1
23	Screw, Cross ST2.9×9.5	8909008	6	50	Nozzle, Injector	8454007	1
24	Locating Board	6380045	1	51	Throat, Injector	8467007	1
25	Fitting Nut	8092007	1	52	Injector Body	8008010	1
26	O-ring 50.39×3.53	8378107	1	53	O-ring 10.82×1.78	8378012	1
				54	O-ring 7.5×1.8	8378016	2

MODEL: F116A1/F116A3/F117A1/F117A3

4. Warranty Card

Dear client:

This warranty card is the guarantee proof of Runxin brand multi-functional flow control valve. It is kept by client self. You could get the after-sales services from the supplier which is appointed by Runxin manufacturer. Please keep it properly. It couldn't be retrieved if lost.

It couldn't be repaired free of charge under the below conditions:

1. Guarantee period expired. (One year).
2. Damage resulting from using, maintenance, and keeping that are not in accordance with the instruction.
3. Damage resulting from repairing not by the appointed maintenance personnel.
4. Content in guarantee proof is unconfirmed with the label on the real good or be altered.
5. Damage resulting from force majeure.

Product Name	 Multi-functional Flow Control Valve for Water Treatment Systems		
Model		Code of Valve Body	
Purchase Company Name		Tel/Cel.	
Problem			
Solution			
Date of Repairing	Date of Examination	Maintenance Man Signature	

When product needs warranty service, please contact with your direct supplier first, after got permission, then fill in the below content and send this card together with the product to the appointed suppliers or Runxin company.

End-user Company Name		Tel/Cel.	
Purchase Company Name		Tel/Cel.	
Model	Code of Valve Body		
Tank Size $\phi \times$	Resin Volume L	Raw Water Hardness mmol/L	
Water Source: Ground-water <input type="checkbox"/> Tap Water <input type="checkbox"/>	Water Treatment Capacity m^3	Backwash Time min	
Brine & Slow Rinse Time min	Brine Refill Time min	Fast Rinse Time min	
Problem Description			