

Residential Softener

RL-R80

RL-R150

User Manual

Please read this manual in details
before using the valve and keep it properly
in order to consult in the future.

0WRX.466.744

Rev.A.202010

Catalogue

Preface.....	2
1. Product Profile.....	2
2. Working Principle	2
3. Assembly & Parts	2
4. Function and Characteristics	3
5. Application.....	5
6. Technical Parameters.....	5
7. Setting and Usage.....	6
7.1 Control Valve Setting and Usage.....	6
7.1.1 The Function of Control Panel and Parameter Setting.....	6
7.1.2 Matching Process of Phone and Softener.....	7
7.1.3 Users Parameters Setting.....	7
7.1.4 Parameter setting method.....	8
7.1.5 Users Condition.....	10
7.1.6 Exit Leakage Protection Status.....	12
7.1.7 Exit Salt Shortage Alarm Status.....	12
7.1.8 Indicator Light.....	12
7.1.9 Technician or Default Parameters Setting and Inquiry.....	13
7.2 Usage of Brine Valve.....	14
7.3 Installation and Usage of Bypass Valve (Optional).....	14
7.4 Operation of Mixing Valve.....	15
7.5 Installation and Usage of Leakage Sensor.....	15
8. Usage Illustration.....	16
9. Notice.....	18
10. Warranty Card.....	21

Note: The design and specifications are subject to the changes without prior notice. We reserve the right of interpretation to the user manual.

Preface

Thanks for choosing our softener series products. These products are featured by good softening effects, stable performance, excellent appearance, compact structure and simple handling, etc. They can meet the soften water demand of family washing, bathing, cleaning, water heater, boiler and etc. Besides, they also can be applied to supplying high quality soften water for institutions, schools, group companies, and so on.

1. Product Profile

The product is working automatically and intelligently. It adopts food-grade cation resin to soften water, efficiently reducing calcium and magnesium ion content of tap water. After the resin is invalid, the regeneration function will automatically control the device to regenerate resin by brine, recovering the softening function of the resin. It can automatically realize the function of brine refill, brine dissolve, backwash, brine & slow rinse, and fast rinse without manual operations.

2. Working Principle

Ion exchange technique is applied to the softener. It can realize the purpose of wiping off the lime scale (Calcium carbonate and magnesium carbonate) through replacing the calcium ion and magnesium ion by the sodium ion of the resin. According to the pre-set program, it can automatically control the open and close of each valve, so as to conduct softening, brine refill, brine dissolve, backwash, brine & slow rinse and fast rinse.

3. Assembly & Parts

Integrated type structure

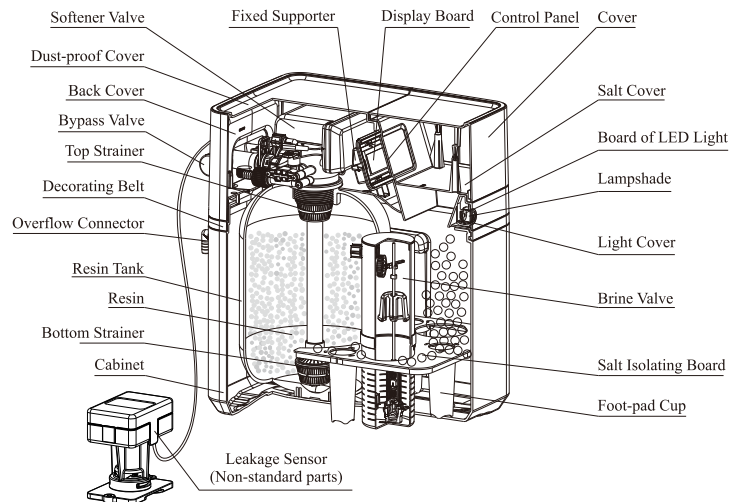

4. Function and Characteristics

WIFI Control Function

Scan QR code to download the app and install it on the phone. Connect the phone with the valve, and the phone can control the valve far away once successfully matched.

Regeneration starts automatically

According to the set hardness of raw water and regeneration time by user, the system will start the regeneration program automatically.

Regeneration starts manually

In unlock status, press “” button to start regeneration immediately.

Water capacity can be calculated automatically

After inputting the hardness value, the control valve will automatically calculate the system water treatment capacity and display on the LCD screen.

Brine dry mode & regeneration with softened water

Under brine dry mode, brine refill starts 4 hours earlier before service finished. It is softened water that refills the tank, which is conducive to enhances the effect of regeneration; While brine refilling and dissolving, the valve is softening water (softened water flows out from outlet). It saves time for regeneration and improves working efficiency.

There is water in brine tank when in brine refill, salt dissolve and backwash status; after brine draw, there almost is no water in brine tank when in fast rinse and service status, and the salt is dry in brine tank, which is brine dry mode.

Brine draw proportionally

When actual water used does not reach the water treatment capacity, but the time reaches the maximal regeneration days, so the softener will have proportional brine draw and brine refill according to the ratio of actual water used and water treatment capacity. It is more reasonable, to achieve the purpose of saving salt and water.

Water hardness can be adjusted



It can adjust the hardness of outlet water by adjusting bolt to mix up a part of raw water with softened water. (See Page 15 The Operations of the Valve with the Function of Mixing Water)

Automatic memory function

The parameters set by users, such as regeneration time, brine refill time, backwash time, brine & slow rinse time, fast rinse time, and so on, can be saved permanently no matter how long the power is off. If power off is more than 3 days, it will always display this interface to remind to reset the time of day (See below picture).

Time of Day
12:12

Buttons lock function

No operations to buttons within 1 minute, buttons are locked. Press and hold the “” and “” buttons for 5 seconds to unlock. This function can avoid incorrect operation.

Regeneration mode is meter delayed type

Regenerates on the day although the available volume of treated water drops to zero (0). Regeneration starts at the regeneration time. It can avoid the shortage of water when regeneration.

Vacation mode

Before travelling, please set the softener to vacation mode. In this mode, the softener will be in brine refill status firstly, and then in salt dissolve and brine draw status (this brine draw time is only 25% of normal brine draw time, that's to say, the resin is totally soaked in brine to avoid losing resin's efficacy). After brine draw finished, the valve will go to the close position or close the inlet valve. After vacation, release from this mode, and softener will start fast rinse — service. It effectively avoids unqualified water caused by not used for a long time, and avoids loss when softener leaks in a system exception situation.

Working automatically

Softening: Under a certain pressure and flow rate, the raw water flows through this device, at the same time, the calcium ion and magnesium ion of raw water are replaced by the sodium ion of resin, reducing the content of calcium ion and magnesium ion and realizing the purpose of softening water.

Brine refill: The brine tank is refilled with soft water to dissolve the salt so as to provide the saturated brine for next regeneration. Meanwhile, there is softened water can be provided from outlet.

Brine dissolve: When control valve turns to service status, brine dissolve will be lasting 4 hours.

Backwash: After the resin is saturated and lose softening efficacy, the program start backwash before regeneration. On the one hand, it can wipe off the broken resin and the impurity on surface layer of resin. On the other hand, the reversed flow direction can loosen the tight resin and make it benefit for the touch between resin particle and regeneration liquid.

Brine & slow rinse: A certain concentration of brine flows through the resin. Meanwhile, the calcium ion and magnesium on the resin surface layer are replaced by the sodium ion, making the invalid resin regeneration and recovering its softening capacity.

Fast rinse: Discharge the residual brine and compact the resin particle so as to reach the best softening effect. By this step, the product automatically finished one service cycle.

Salt shortage alarm

Input the total salt quantity one time added, the program will automatically calculate the regenerated salt consumption according to the resin volume. When the amount of salt remaining in the salt tank is less than the consumption for single regeneration, the softener will display “Check Remaining Salt”

in service status, and red light will flash. When the salt added quantity is set to zero (0), this function can be turned off.

Resin maintenance or Call for Check-up

The system will automatically calculate the regeneration times. When the resin is almost invalid, the display in service status will show “Maintenance/Call for Check-up”.

Leakage protection function

It is equipped with an auto shut-off valve (non-standard parts) containing induction sponge or set the continuous water outlet time and the maximum instantaneous flow rate to close the water inlet of the control valve, which can reduce the loss caused by water leakage in the back-end piping system of the machine under abnormal situation.

5.Application

The product can be used for treating the tap water or other qualified raw water.

6.Technical Parameters

Product Parameters:

Model	Rated Flow Rate (L/h)	Suggested Flow Rate (L/h)	Water Capacity Per Cycle (L)	Rated Treated Water Quantity (m ³)	Brine Tank Size(in)	FRP Tank Dimension (Φ×h) mm	Cation Resin Volume (L)
RL-R80	1600	800~1600	2700	9500(950)	1015	258×381	11
RL-R150	3000	1000~3000	7000	22500(2250)	1035	258×891	28

※Water treatment capacity per cycle is various according to the difference water quality of different region.

The standard testing conditions is:

Water temperature: 25℃

Raw water hardness: 150mg/L(CaCO₃).

※The outlet water conforms with the regulations (2001) of Safety and Function Assessment for Drinking Water Treatment Device— General Treatment Device.

※Transformer— Input : AC100~240V / 50Hz~60Hz; Output: DC12V / 1.5A

Service Conditions:

Water Pressure: 0.15-0.6MPa;

Electrical Facility: AC100~240V / 50Hz~60Hz;

Water Temperature: 5~38℃

Environment Temperature: 4~40℃

Relative Humidity: ≤90% (25℃)

7. Setting and Usage

7.1 Control Valve Setting and Usage

7.1.1 The Function of Control Panel and Parameter Setting

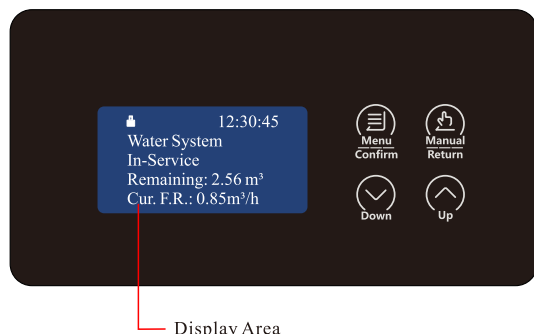

A. Button lock indicator

● lights on, indicates the buttons are locked. At this moment, it is useless to press any single button (Under any status, no operation in one minute, will lights on and locks the buttons.)

● Solution: Press and hold both and for 5 seconds, the lights off.

B. Menu/Confirm button

● In service status, press to enter program setting status. Select the setting item can view the value.

● Press under setting enquiry status, data flickers, enter setting status and modify parameter value.

● Press after all program are set, and then the voice “Di” means all setting are success and return program display mode.

C. Manual/Return button

● Press in service status, it can proceed to next step. (Example: When the hardness of treated water is unqualified, press at unlock status to finish service, enter to regeneration instantly. When at regeneration status, press can enter to next step.)

● Press in enquiry status, and it will return to menu status; Press in program set status, and it will return to menu status.

● Press while adjusting the value, then it will return program display mode directly without saving value.

D. Down and Up

● In menu status, press or to view all values

● In setting status, press or to adjust the parameter.

● Press and hold both and for 5 seconds to lift the Button Lock status.

7.1.2 Matching Process of Phone and Softener

① Firstly, download and install correct APP by scanning QR code as shown Figure 1.

② If installation successfully, there is “RUNXIN” APP on cell phone. Then register and login to match the cell phone with control valve.

③ Switch to configure interface, as Figure 2 shows, click , the screen shows as Figure 3; Click , the screen shows as Figure 4.



Figure 1



Figure 2

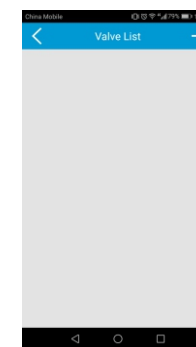

Figure 3

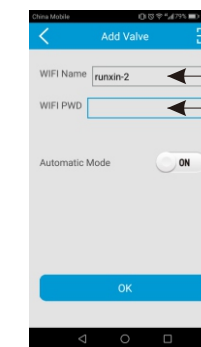
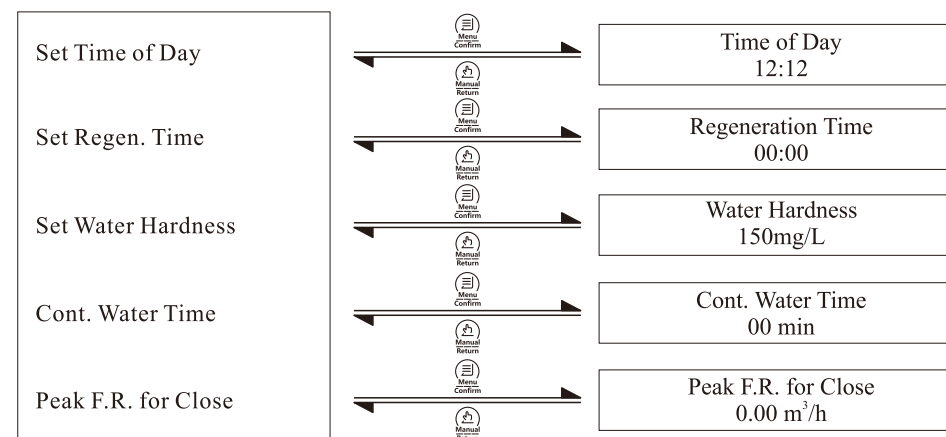

Figure 4

WIFI Account
WIFI Password

④ As Figure 4 shows, input the password. After power off, reconnect power and press on valve until heard a sound of DI, then press OK button in 5 seconds on cell phone. After matching, users can operate valve on cell phone.

7.1.3 User Parameter Setting



Item	Parameter Set Range	Factory Default	Actual setting
Time of Day	00:00~23:59	Current time	
Regeneration Time	00:00~23:59	00:00	
Water Hardness	50~999mg/L	150mg/L	
Continuous Water Time	00~120min (This function will be invalid when set as 0)	00	If the actual continuous water time is longer than the set value, the control valve will turn to close status automatically.
Current Flow Rate	0.00~10.00m ³ /h (This function will be invalid when set as 0)	0.00	If the actual flow rate exceeds the set value, the control valve will turn to close status automatically.

7.1.4 Parameter Setting Method

(1) Unlock

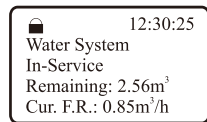

Locked state



Press and hold "Down" and "Up" button for 5 seconds until the "Lock" light off and the unlocking is successful.

(2) Time of Day



Press the "Menu" button in the working state, enter user parameter setting interface

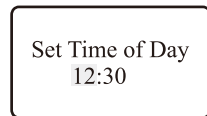

Time of Day parameter interface, The hour number 12 flashes, press the "Down" or "Up" button to adjust the hour number.

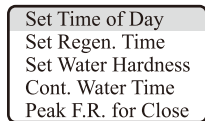

System default "Set Time of Day" chosen.



Press the "Menu" button, the Time of day minutes 30 flashes, press the "Down" or "Up" button to adjust the minutes.



Press the "Menu" button, enter the "Set Time of Day" interface



Press "Menu" button and hear a sound "Di", Time of day is saved, and the setting is successful.

(3) Regeneration Time



Press the "Menu" button in the working state, enter user parameter setting interface



Regen. Time setting interface, The hour number 00 flashes, press the "Down" or "Up" button to adjust the hour number.

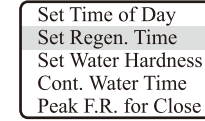

Press the "Down" button to select "Set Regen. Time" item



Press the "Menu" button, the Regen. Time minutes 00 flashes, press the "Down" or "Up" button to adjust the minutes.



Press the "Menu" button, enter the "Set Regen. Time" interface



Press "Menu" button and hear a sound "Di", Regen. time is saved, and the setting is successful.

(4) Water Hardness



Press the "Menu" button in the working state, enter user parameter setting interface

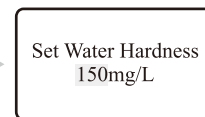

Water Hardness setting interface, The hardness value of 150 flashes, press "Down" or "Up" button to adjust the hardness value of raw water.

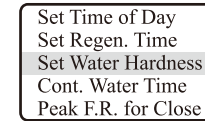

Press the "Down" button to select "Set Water Hardness" item



Press "Menu" button and hear a sound "Di", Water Hardness is saved, and the setting is successful.



Press the "Menu" button, enter the "Set Water Hardness" interface

(5) Cont. Water Time



Press the "Menu" button in the working state, enter user parameter setting interface

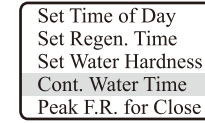

Press the "Down" button to select "Cont. Water Time" item



Press the "Menu" button, enter the "Cont. Water Time" interface

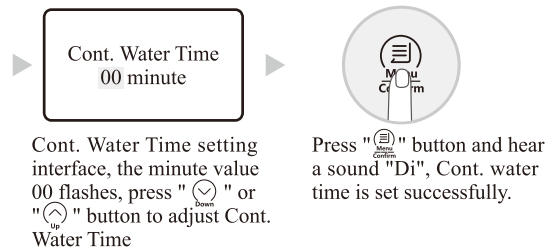

(6) Peak F.R. for Close

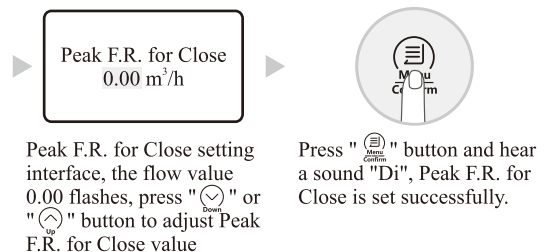
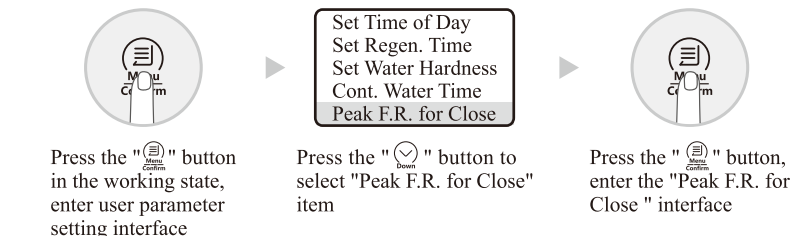

Illustration: After setting the water hardness, the display screen will show the total water treatment capacity or remaining water. **If you think the water treatment capacity is too low to meet your demand, you can adjust the capacity by setting the water hardness. Under the condition of not affecting the outlet water quality, lowering the water hardness value can increase the water treatment capacity.**

7.1.5 User Condition

After power on, it will show below figure 6 seconds and then enter into user mode.

```

*****
Model No.
*****

```

Process display example: The meter type softener valve (Take up-flow regeneration type as example)

12:30:45 Water System In-Service Remaining: 2.56m ³ Cur. F.R.: 0.85m ³ /h G1	12:30:45 Water System In-Service Remaining: 2.56m ³ Regen. Tim:00:00 G2	12:50:32 Water System Brine Refilling... Remaining: 08:30 min.:s. G3
12:53:32 Water System Softening... Remaining:240min. Cur. F.R.: 0.85m ³ /h G4	16:54:32 Water System Backwashing... Remaining: 3 min. G5	16:58:32 Water System Brine & Slow Rinse... Up-Flow Remaining: 40 min. G6
17:04:32 Water System Fast Rinsing... Remaining: 7 min. G7	Motor Running... G8	System Error! **EX** G9

Illustration:

- In Service status, the figure shows G1 and G2; In Brine Refill status, it shows figure G3;
- In Brine Dissolve status, the figure shows G4; In Backwash status, it shows figure G5;
- In Brine & Slow Rinse status, it shows figure G6; In Fast Rinse status, it shows figure G7;
- When the electrical motor is running, it shows figure G8; The display will show figure G9 when the system is in error. X of EX stands for number 1 to 4.

In vacation mode, it shows "VAC. MODE" as below figures:

12:50:32 Water System VAC. MODE Brine Refilling... Remaining: 05:30 m:s	12:50:32 Water System VAC. MODE Pause 1... Remaining: 240 min	12:50:32 Water System Brine & Slow Rinse... VAC. MODE: Up-Flow... Remaining: 10:00 m:s	12:50:32 Water System VAC. MODE Pause 2...
---	---	--	---

Enter vacation mode

In service mode of unlocked status, press and hold “” for 6 seconds to enter vacation mode with buzzer sounding and electrical motor running. Firstly, it enters Brine Refill status. Secondly, it turns to Pause 1 status for 240 minutes Brine Dissolve status after Brine Refill. Thirdly, it is in Brine & Slow Rinse status after Brine Dissolve (Time of brine drawing is 25% of the normal setting). After Brine & Slow Rinse, it turns to Pause 2 status.

Exit vacation mode

In Pause 2 status of unlocked status, Press and hold “” for 6 seconds to exit vacation mode with buzzer sounding and electrical motor running. Control valve turns to Fast Rinse status. After that the valve turns to service mode.

7.1.6 Exit Leakage Protection Status

Release the leakage protection status in normal status

02:01:30
Water System is closing.
After unlock, press ▼ key for 5
seconds to service status.

G10

When the valve shows Figure G10, it indicates that leakage has occurred in normal status and the valve is in the closed protection position. After solving the leakage problem, press and hold the DOWN button for 5 seconds in the unlocked state, it will exit the water leakage protection and enter the service status to supply water.

Release the leakage protection status in vacation mode

02:01:30
Water System is closing.
After unlock, press ▼ key for 5
seconds to F.R. status.

G11

When the valve shows Figure G11, it indicates that leakage has occurred in vacation mode and the valve is in the closed protection position. After solving the leakage problem, press and hold the DOWN button for 5 seconds in the unlocked state, it will exit the water leakage protection and enter the fast rinse status, after fast rinse, the valve will enter the service status to supply water.

7.1.7 Exit Salt Shortage Alarm Status

When the valve shows Figure G12, it indicates that brine tank maybe lack of salt. After adding salt, press DOWN button for 3 seconds can back to service status to supply water.

03:00:30
Check Remaining Salt
Press ▼ 3s to clear

G12

7.1.8 Indicator Light

The meanings of different colors and status of indicator light:



Indicator Light

Light color	Meaning
Green light keeps on	Service status
Yellow light keeps on	Regeneration status
Red light flashes	Salt shortage status

7.1.9 Technician or Default Parameters Setting and Inquiry

When power on, press and hold both “” and “” for 2 seconds at least, then system will enter technician or default parameters inquiry. Press “” or “” to inquire below parameters. (Press “” to exit the inquiry status):

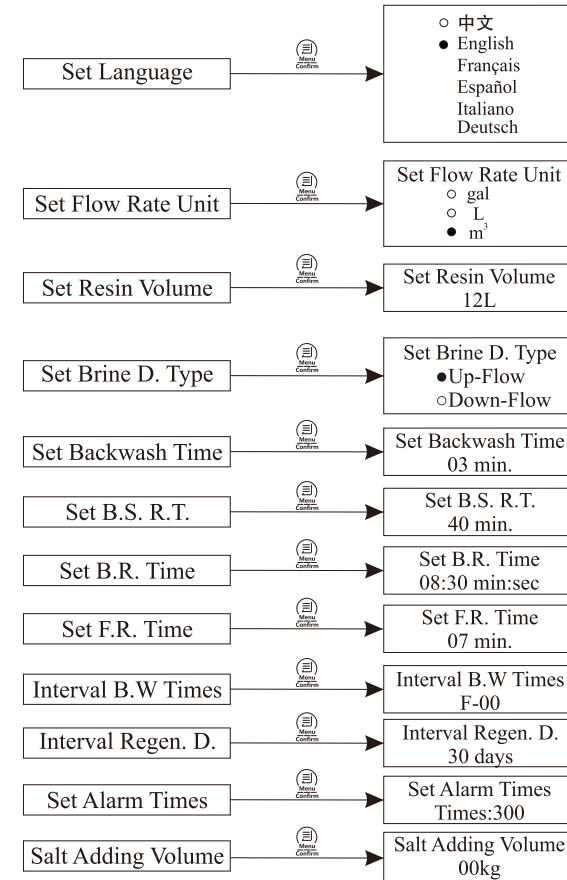

Parameter setting: In inquiry status, press “” or “” to set the parameter directly.

Item	Parameter Set Range	Factory Default	Remark
Set Language	Chinese/ English/ Français/Español/ Italiano/Deutsch	English	/
Set Flow Rate Unit	gal、L、m ³	m ³	
Set Resin Volume	1~75L	See parameter table	

Set Brine D. Type	Up-flow/ Down-flow	Up-flow	/
Set Backwash Time	00~99min	See Table 1	Backwash time (min)
Set B.S. R.T.	00~99min	See Table 1	Brine draw & slow rinse time (min)
Set B.R. Time	00:00~99:59m:s	See Table 1	Brine refill time (m:s)
Set F.R. Time	00~99min	See Table 1	Fast rinse time (min)
Interval B.W Times	0~20	00	Only available for up-flow type
Interval Regen. D.	0~40	30	
Set Alarm Times	5~1200 times	300	The value can not be too small, otherwise, the system will display "Call For Check-up" only regenerate a few times.
Salt Adding Volume	0~100Kg	00	When set 0, it indicates that close this function. Add salt and set value according to Table 1 to open this function.

Table 1

Resin Tank	Parameter (Factory Default)			
	Backwash Time (min)	Brine Draw & Slow Rinse Time (min)	Brine Refill Time (m:s)	Fast Rinse Time (min)
1015	03	40	12:50	06
1035	05	60	28:00	09

The working process of meter type softener valve:

Service → Brine Refill → Salt Dissolve → Backwash → Brine & Slow Rinse → Fast Rinse → Service (Cycle repeats).

7.2. Usage of Brine Valve

- ① Under the brine and slow rinse status, with the floating ball, the brine valve can prevent the air from being inhaled which may affected the regeneration and usability. That is, the brine valve has the function of air check.
- ② Under the brine refill status, the brine valve can control the volume of refilling water by controlling the position of floater and control salt consumption.

7.3. Installation and Usage of Bypass Valve (Optional)

The valve has the function of bypassing. When the piston is pushed to the position of inlet and outlet, the valve is in service status; when it is at bypass position, the valve is in bypass status. It adopts quick joint structure to connect the valve with bypass valve, with the characteristics of reliable sealing, quick and convenient installation.

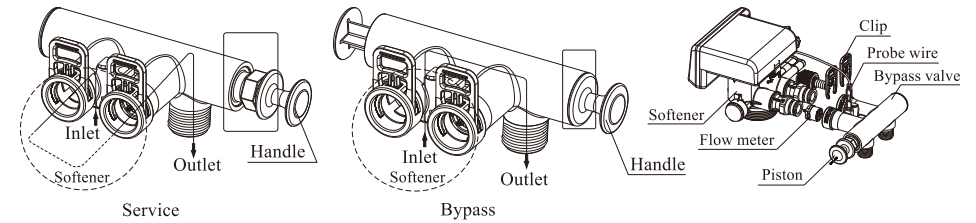

7.4. Operation of Mixing Valve

If the users think the hardness of outlet water is too low, they can adjust the hardness by using the function of mixing water according to the actual demand.

Operation: Anticlockwise rotate the adjusting bolt. The wider angle is, the higher outlet water hardness will be.

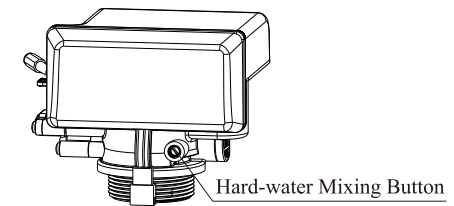

7.5. Installation and Usage of Leakage Sensor

The installation of leakage sensor can be done by double sticky tape or expanding bolt. The leakage sensor should be located on the ground where is near the residential softener and easy to detect leakage.

• Single monitor installation

① Double sticky tape installation

Tear off the protective layer of the double sticky tape and fix it on the ground. The sticking position should be dry and clean.

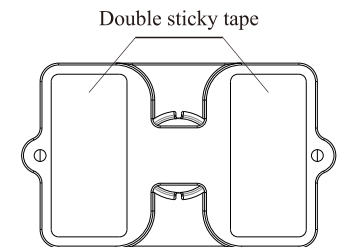

② Expanding bolt installation

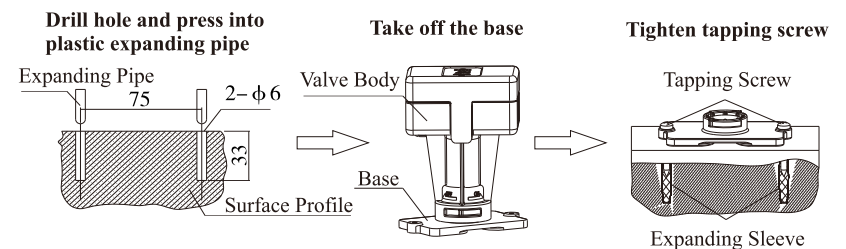

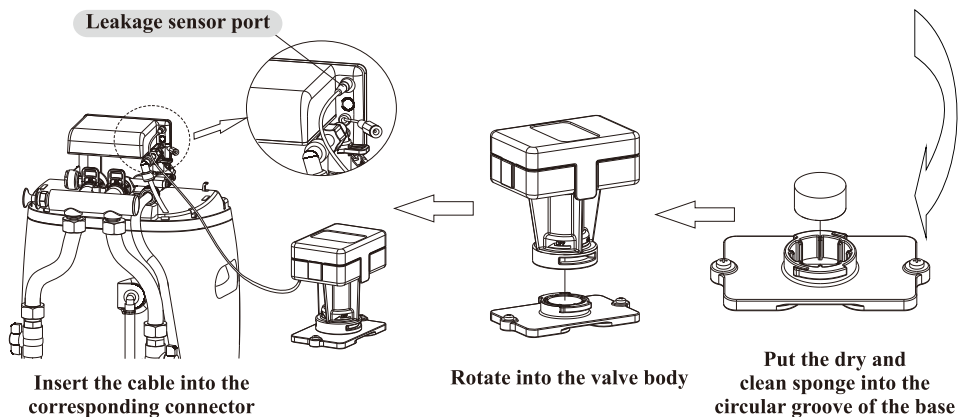

Notice: Control valve will always be closed once the absorbent sponge of leakage sensor absorbs water until change a new sponge. It will return to properly monitoring after press and hold the button “”.

8.Usage Illustration

After installing the device and setting the relevant parameters, please conduct the trial running as follows:

1. Fill the brine tank with 3-7L water and start the device. (This step is necessary only for the situation that the device is put into use for the first time. The softener will refill the water automatically when works normally. When the brine refill time is reached or the water level reaches the height set by the brine valve, the brine refill is stopped, and the saturated brine is produced for the next regeneration; the following table values for reference that are the water volume required for the saturated brine for once regeneration.)

Resin Tank	1015	1035
Water (L)	5.5	11.5

2. Switch on power. Press “” and go in the backwash status. Slowly open the inlet valve to 1/4 position (Avoiding to open the valve too quickly to damage the device and make the resin run off). At this moment, you can hear the sound of air-out from the drain pipeline. After all air is out of pipeline, then open inlet valve completely and conducting 2~3 minutes backwash, cleaning the foreign materials in the resin tank until the outlet water is clean.

02:08:00

Water System
Back Washing...
Remaining: 3 min.

Backwash Status

3. Press “” and turn the status from Backwash to Brine & Slow Rinse. Under this status, the brine will be absorbed from the brine tank into the resin and the resin is regenerated. After absorbing, the brine valve will close. The system will still conduct about 15 minute’s slow rinse, wiping off the residual brine. The whole process will take about 40 minutes to finish. (It can be without adding salt when debug, use tap water to test the function and system seal.)

02:40:25

Water System
Brine & Slow Rinse...
Up-flow
Remaining: 40 min.

Brine & Slow Rinse Status

4. Press “” and turn into Fast Rinse status. About 7 minutes fast rinse will discharge the residual brine and compact the resin particle so as to reach the best softening effect.

03:25:50

Water System
Fast Rinsing...
Remaining: 7 min.

Fast Rinse Status

5. When the sample outlet water is qualified, press “” and finish the Fast Rinse. Then the device turns into Service status and start running.

12:30:25

Water System
In-Service
Water
Remaining: 2.56m³
Cur. F.R.: 0.85m³/h

or

12:30:25

Water System
In-Service
Water
Remaining: 2.56m³
Regen. Time: 00:00

Service Status

Illustration:

- (1) Under regeneration cycle, the softener water will stop flowing out from the outlet and each status will be completed automatically according to the setting time. If you want to finish one step in advance, you can press “”.
- (2) During the trial running status, check each status. There should no mineral media flow out. Check each connection to ensure there is no leakage.
- (3) The time of brine refill, backwash, brine & slow rinse, fast rinse, etc. could be suggested by dealer or professional personnel.

Notice: Under normal situation, user does not need to do any operation except adding a certain amount of salt into the brine tank.

9. Notice

Before reading and understanding the user manual, please do not operate the device.

※ Before installation and trial testing the product, please take out the spare parts kit and filling material from the cabinet.

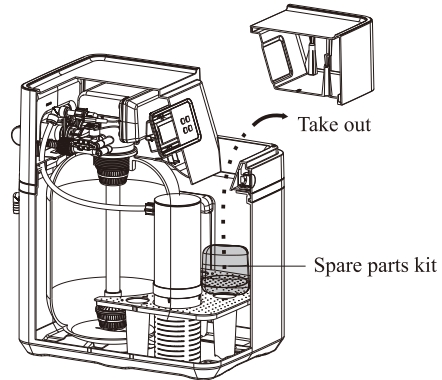

※ To ensure normal operation of the product after installed, please consult with professional installation or repairing personnel before use it.

※ Forbid installing the device near heat source or take anti-heat protective measures when install near the heat source. It is also forbidden to connect the device with the hot-water pipeline or the pipeline with the possibility of hot-water returning. Forbid the product under the temperature lower than 1°C. Protect resin from freezing which may result in resin broken and disabled.

※ Do not install the device near the place with acid or alkali substance or air, in case of the corrosion to the device.

※ If the device is connected before hot water boiler or water heater, a check valve is needed, in case the hot water flowing back and damage the device.

※ To ensure the safety, there must be a floor drain within 1 meter around the equipment installation. A separate drainage for the device is needed. The drainage connector should be prevented water flowing back. Stuck drainage or siphon should be avoided in case the drain water flow back from the drain pipeline or brine tank to the device.

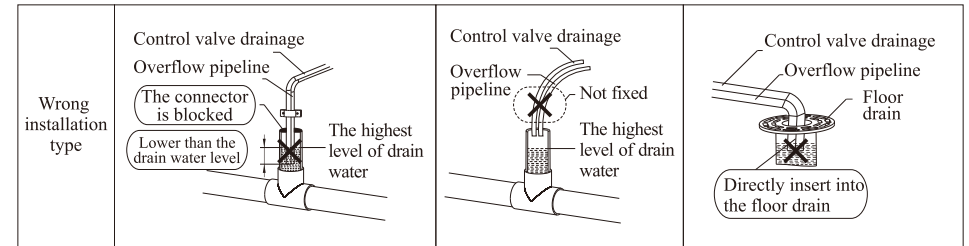
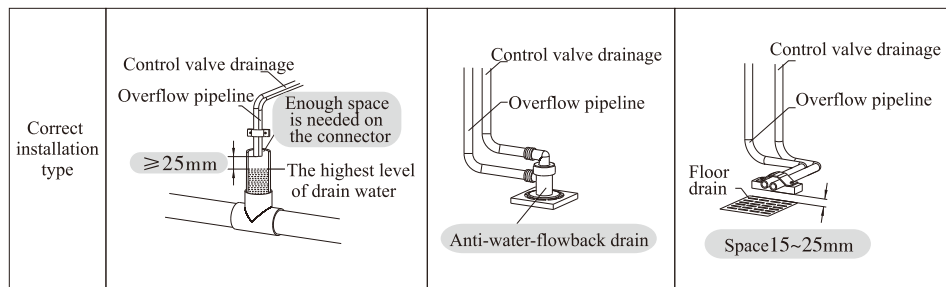

Warning: Be sure to install the drainage pipeline correctly! Quality accidents, such as sewage overflow, blocked drainage or blocked floor drain caused by improper installation are not covered by our company's warranty and compensation.

※ Each inlet and outlet pipeline is qualified with provincial sanitation department check and every installation is conform to the local installation regulations.

※ It is suggested to used soft tube to connect with inlet, outlet, drainage and overflow connector. (Notice: the material of the connecting pipes and valves should use 304 stainless steel, alloy steel or high strength engineering plastic. Ionic material is forbidden.)

※ Use reagent to test raw water hardness, as the raw water hardness is closely related to the effect of softener and water treatment capacity. Use this softener under the condition that raw water hardness < 450mg/L.

※ If the raw water fails to meet the standards of local tap water, such as the sediment concentration or residual chlorine content exceed the stand, etc., the pretreatment device should be installed in front of the device. (Such as Y type filter, ultra filter, activated carbon filter and so on.)

※ During the operation, please check the brine tank regularly to ensure there is brine in the tank. And when adding brine, please make sure that salt level is higher than water level (see picture I). When the salt level is lower 1/3 of water level (see picture II), please add in time. (Attention: Make sure the dissolving salt time is more than 4 hours so as to make the brine saturate.)

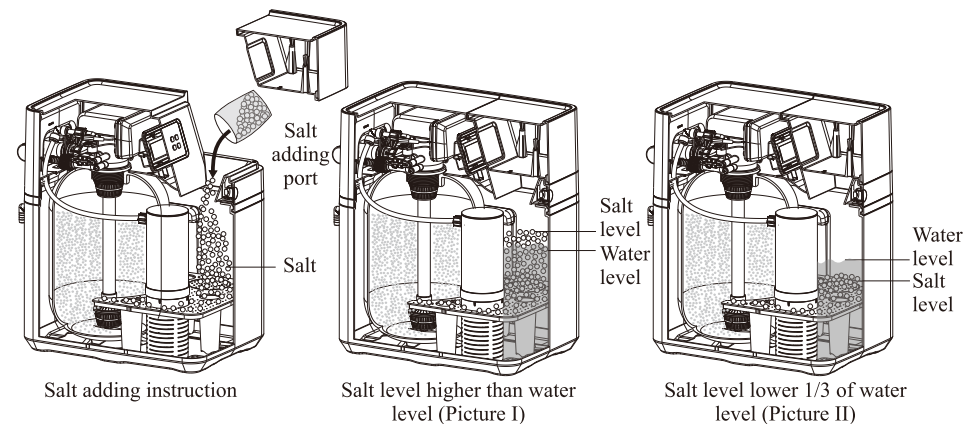

※Please strictly use the salt of more than 99% purity only. Any salt with additive or large particles is forbidden to add.

※Please use this product under the water temperature between 5~45℃, water pressure 0.15~0.6MPa. Failures in the use of this product outside this range are not covered by our company's responsibility and warranty.

※Sodium used in the water softening process should be considered as the part of your overall dietary salt intake. Please install purification equipment at the drinking water end if you are on a low sodium diet and contact doctor for further confirmation.

※Soft water is not recommended for direct drinking, it can be used as domestic water.

※Without being used for a long time or the pressure of the inlet water is instable, please close the inlet port and turn off the power. Before using again, please firstly conduct a regeneration cycle through manual operation so as to ensure the quality of soften water.

※If there is a power failure during the regeneration, the water will be drained continuously, please check if the machine is regenerating when the power is off.

※During the service of product, prevent water hammer happened. Do not make these operations, such as quickly and fully opening valve, or quickly and fully closing valve or shut off water pump, etc.

※If the water demand is increasing (Compared to usual demand) or the hardness of raw water is rising, please reduce the regeneration cycle and increase the regeneration times, ensuring the soften water yield.

※When use the softener for the first time or the device is idle for long period, it is normal that the outlet water is yellow. Please put into use after 2~3 minutes' rinsing.

※Sometimes the salt in the brine tank will forms salt bridge. That is, there is a space under the salt which prevents the salt from being dissolved and hinders the resin regeneration. It is suggested to check regularly. If there is salt bridge, please mash it.

※During regeneration period, there is no softened water for using. But if it still needs water for using, it is not suggested to bypass big quantity of hard water, it may affect the regeneration efficiency.

※If the display board displays 12:12 and flashes, it means power off (more than 3 days) to remind to reset the time of day. If power off within a short time, the system has memory function, do not need to reset the time.

※Check the softener regularly, checking item:

- a) If there is any pipeline leakage. If it does, contact with your seller.
- b) If the overflow connector blocked, if it does, clean it.
- c) If the brine well in vertical. If it doesn't, put it in vertical (See picture on the right)

※As the product is constantly updating, the possibility that the manual instruction can't accord with the product may happen. So, it is subjected to the actual product.

Special notice: The water pressure of tap water is changeable (Normally the pressure in night

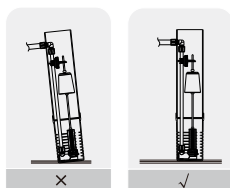

time is higher than day time), so pay attention to each connection to check if there is any leakage at the first two days after products installed.

10. Warranty Card

Dear client:

This warranty card is the guarantee proof of our softener. It is kept by client self. You could get the after-sales services from the supplier. Please keep it properly. It couldn't be retrieved if lost. It couldn't be repaired free of charge under the below conditions:

1. Guarantee period expired. (One year from the manufacturing date);
2. Damage resulting from using, maintenance, and keeping that are not in accordance with the instruction;
3. Damage resulting from repairing not by the appointed maintenance personnel;
4. Content in guarantee proof is unconfirmed with the label on the real good or be altered;
5. Damage resulting from force majeure.

Product Name	Residential Softener			
Model		Code of Valve Body		
Purchase Company Name		Tel/Cel.		
Problem				
Solution				
Date of Repairing		Maintenance Man Signature		Date of Accomplishment